

SFC-KOENIG

Leader in
Sealing & Flow Control
Technology



SFC KOENIG® Product Catalog

┆ KOENIG EXPANDER® KOENIG CHECK VALVE® KOENIG RESTRICTOR® ┆



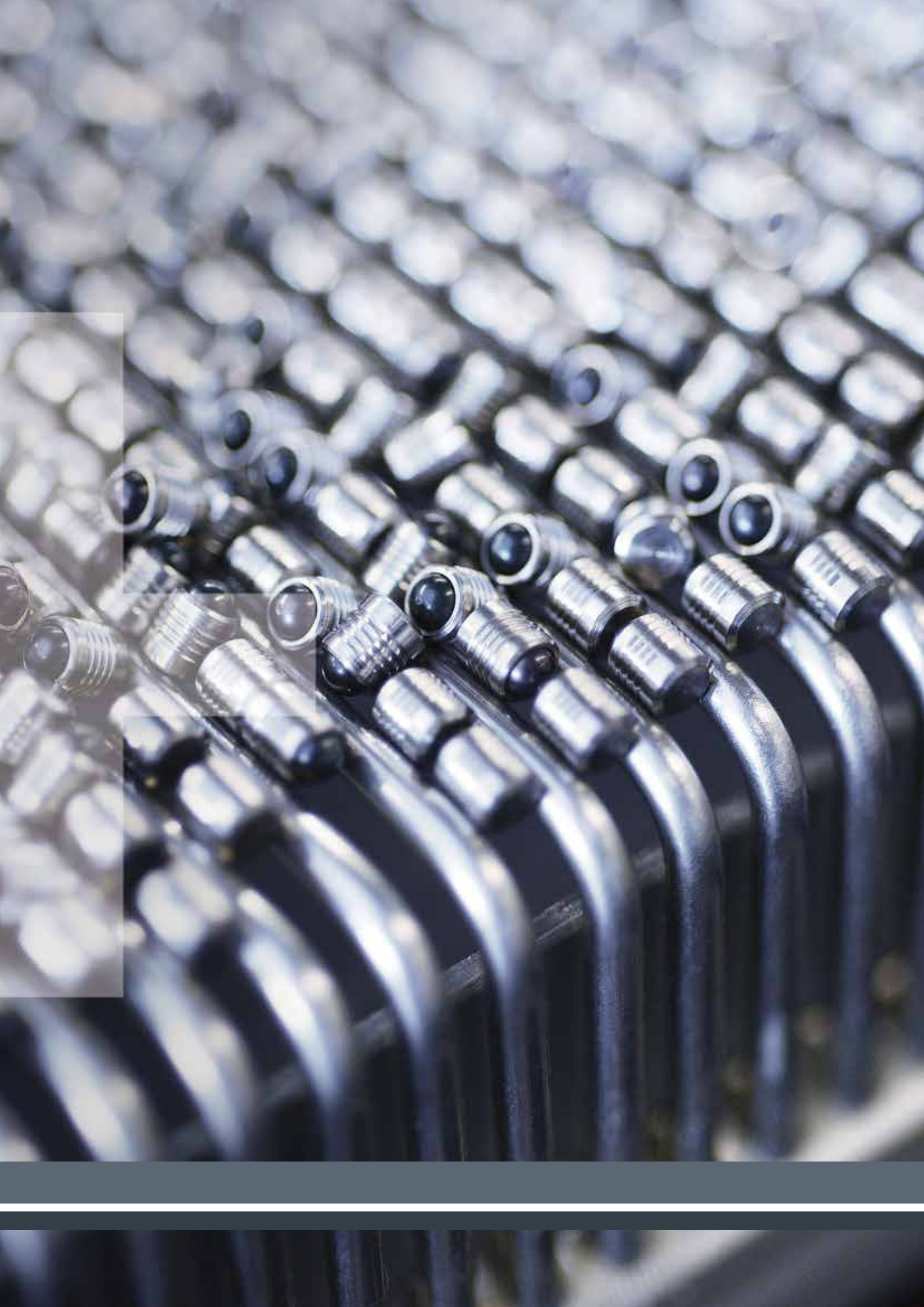

The World's Leading Sealing & Flow Control Technology

With over 3 billion parts installed and failure rates less than 1 part per million, SFC KOENIG® is recognized around the world for reliable, safe and effective sealing and flow control. With our unique expanding seal technology our parts reduce contamination, withstand high pressures and provide leak-free performance for long life cycles.

SFC KOENIG is the original inventor of the one piece, metal-to-metal sealing solution, the KOENIG EXPANDER®, and all SFC KOENIG components are recognized for best-in-class performance in even the most critical applications.

With over 80 years of experience, SFC KOENIG is ready to deliver a solution designed for your application and can integrate our products into your production and workflow processes. Our expert engineers are ready to design a custom part to meet your specific requirements, and we offer a wide variety of standard sizes, designs and configurations for our full line of easy-to-install components.

SFC KOENIG

Leader in
Sealing & Flow Control
Technology



Proven Precision & Reliability

SFC KOENIG components are proven effective in a diverse array of applications, and are the ideal solution wherever safe and secure sealing and flow control is needed. We maintain a variety of manufacturing and industry-specific certifications, and our engineers are ready to assist with a customized solution that meets your exact specifications and requirements. With over 3 billion parts installed, SFC KOENIG components are proven effective and are ready to meet your toughest sealing and flow control challenge.



FLUID POWER

SFC KOENIG parts are ideal for hydraulics, manifolds, mobile power units, valves, pumping and other fluid power systems. We deliver reliable, leak-free sealing and flow control, with tamper-proof designs that provide long life cycles and withstand the harshest environments.



TRANSPORTATION

Leading automotive and vehicle system manufacturers rely on SFC KOENIG solutions for optimized safety and reliability. We maintain ISO/TS 16949 certification and our parts are proven reliable for the operational extremes and high-vibration levels found in engines, transmissions, turbo chargers, braking, fueling and transportation .



MEDICAL

Offering the highest levels of safety, security and dependability, SFC KOENIG components meet the strict requirements of medical, surgical, optical and dental applications. From life-saving equipment to environmental controls, our best-in-class performance is relied on in even the most mission-critical applications.



OFFSHORE & MARITIME

The corrosive, harsh conditions found in maritime and offshore applications are reliably handled by SFC KOENIG components. Our sealing and flow control solutions have been used a diverse array of applications, including shipping, natural gas compressors, pumps, fluid density probes and more.



AEROSPACE

The aviation and aerospace industries rely on SFC KOENIG components for lightweight, high-pressure performance. From flight controls to jet engines, our parts provide safe and effective sealing and flow control in extreme environmental conditions. SFC KOENIG also maintains EN 9100, SAE AS 9100/9110/9120 and JISQ 9100 certification standards, allowing us to work with a variety of aerospace companies around the world.

Unrivaled Sealing & Flow Control Solutions

KOENIG EXPANDER®

The KOENIG EXPANDER® is the original one-piece, metal-to-metal sealing solution. With over 3 billion parts installed and a failure rate less than 1 PPM (part per million), these no-leak sealing plugs permanently resist pressures up to 500 bar and are proven effective – even for the sealing of angled channels and deep holes. The KOENIG EXPANDER® offers easy installation for a variety of applications and configurations, and is the industry's leading technology for the sealing of drilled holes.

KOENIG CHECK VALVE®

With its self-contained, ball-style design and stainless steel construction, the KOENIG CHECK VALVE® provides precise flow control and minimal leakage, leveraging proven SFC KOENIG expander sleeve technology and flow control expertise to provide a highly-accurate solution. Available in a variety of sizes, cracking pressures, and in forward-flow and reverse-flow designs, the KOENIG CHECK VALVE® is effective for fast and dependable flow control.

KOENIG RESTRICTOR®

Designed for accurate flow control in even the most precise applications, the KOENIG RESTRICTOR® is ideal for deep-hole installations and wherever dependable, no leak fluid restriction is needed. The KOENIG RESTRICTOR® is available in a variety of orifice sizes customized for your flow rate, and is offered with or without an integrated screen, providing a reliable, one-piece flow control solution.

MATERIAL / PRESSURE

PUSH-TYPE EXPANDERS

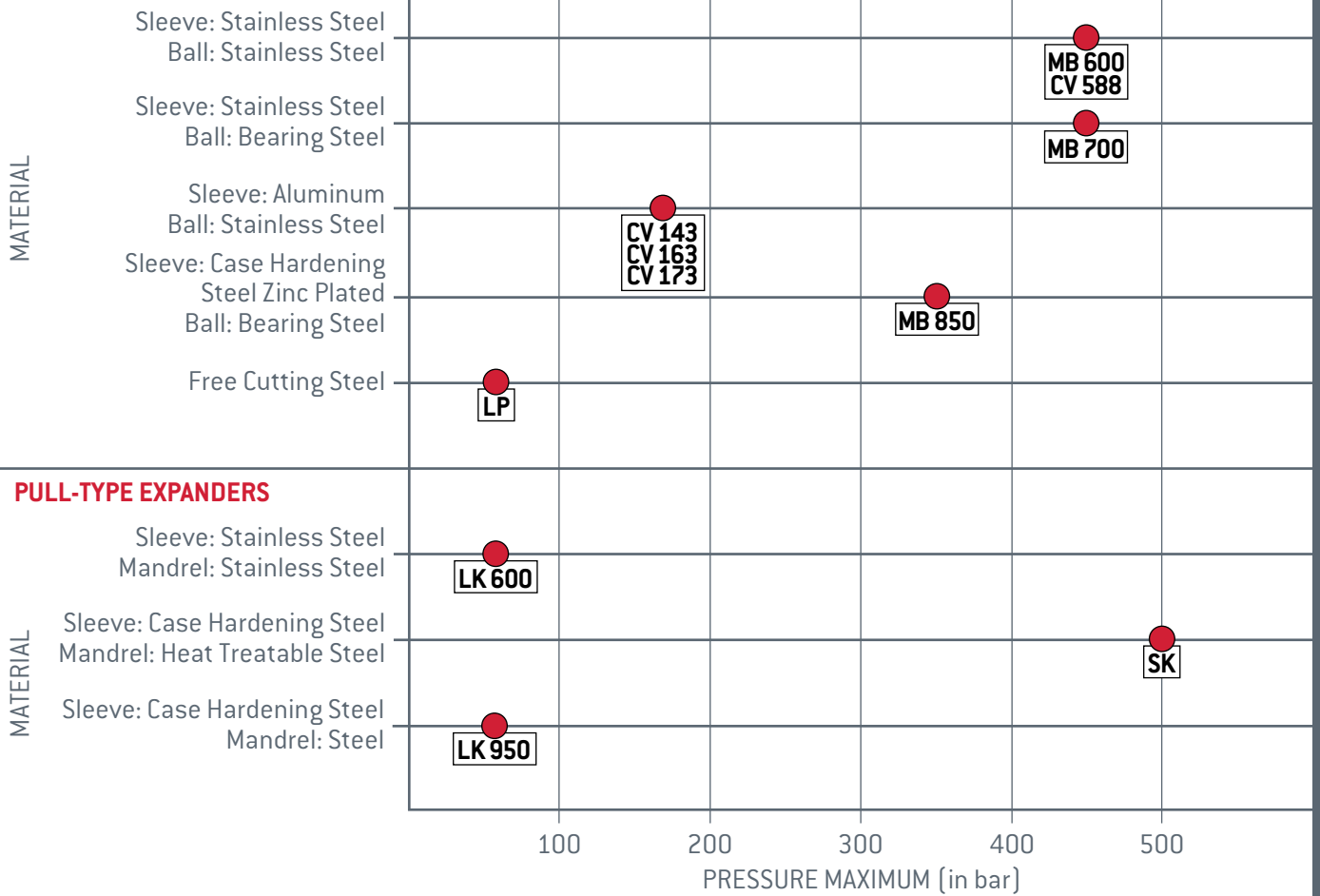

FLOW RATE / PRESSURE

FUNCTIONS

CHECK VALVE

- Opening Pressure: Allow the flow from e.g. 1 bar in flow direction 
- Control fluid pressure in circuits
- Backflow prevention

RESTRICTOR

- Flow Limiter: Control the amount of fluid being supplied
- Orifice diameters customized to your flow requirements

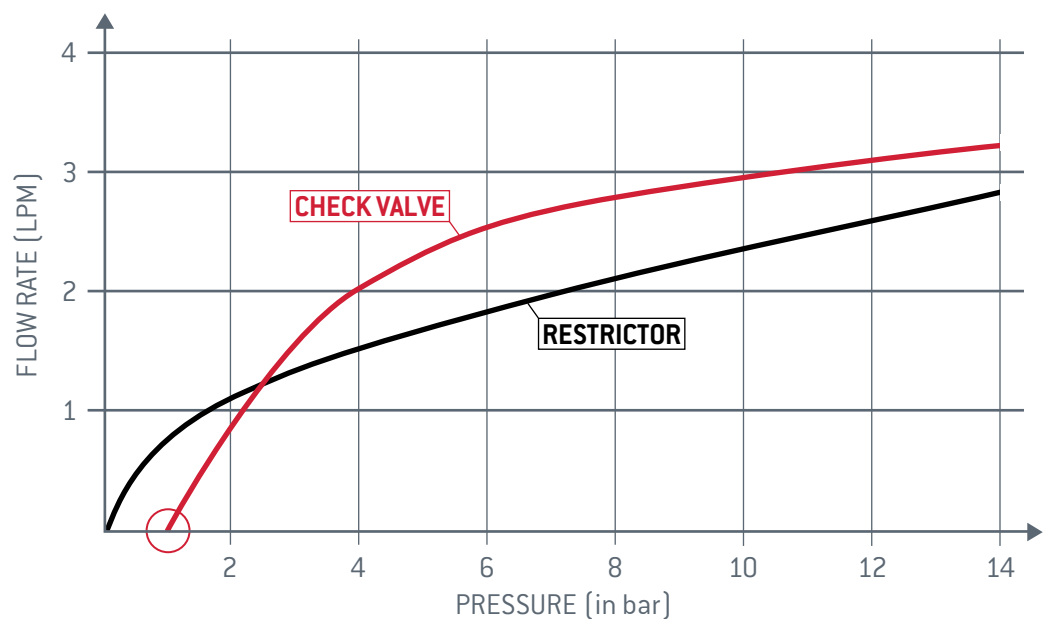

Content

PUSH-TYPE EXPANDERS / PAGES 8–39

KOENIG EXPANDER® plugs effectively seal drilled holes. These parts feature a serrated sleeve which expands as the ball is inserted, enlarging the part to the needed size and sealing the hole. For installation, push-style expanders require a hole drilled with a counter bore.



SERIES MB / CV / Pages 8–39

- Sealing plugs for operating pressures up to 450 bar / 6500 psi
- Wide range of sizes from Ø 3mm – 22mm
- Corrosion-resistant versions available
- Fast, easy installation

LOW-PRESSURE EXPANDERS / PAGES 50–53

Based on a press fit and anchoring concept, low-pressure style expanders use a conical press-in sleeve. During installation, the press-in sleeve adapts to the bore and the outer serration bites into the bore wall.

SERIES LP / Pages 50–53

- Sealing plugs for operating pressures up to 60 bar / 850 psi
- Short installation dimensions
- Mechanical sealing using press fit
- Quick installation



PULL-TYPE EXPANDERS / PAGES 40–49

Pull-style expanders use an integrated mandrel to insert the expander plug into a drilled hole. This type of KOENIG EXPANDER® does not require the hole to be counter-bored, and is often used for angled channels or installations with difficult orientations. They are ideal for installations with space or weight constraints.

SERIES SK / Pages 40–45

- Sealing plugs for operating pressures up to 500
- Short installation length
- Liberal manufacturing tolerance $\varnothing + 0.12\text{mm}$ /
- Extended mandrel for deeper setting

SERIES LK / Pages 46–49

- Sealing plugs for operating pressures up to 60 bar / 850 psi
- Short installation dimensions
- Liberal manufacturing tolerance $0 -/+ 0.12\text{ mm}$
- Comprehensive product range for $\varnothing 4 - 18\text{ mm}$



FLOW CONTROL / PAGES 54–69

The KOENIG RESTRICTOR® is designed to restrict flow in fluid systems and is available in a variety of orifice sizes. The KOENIG CHECK VALVE® controls the flow of fluids and is available in a variety of cracking pressures.

CHECK VALVES / Pages 54–59

- Forward-flow and reverse-flow types available
- Pressure rated up to 300 bar / 4350 psi
- Standard units available in 1 bar +/- 0.3 bar cracking pressures
- Other cracking pressures available upon request
- Stainless steel design is standard
- Available in a range of standard size diameters and flow rates



SERIES RE, RT and RP - RESTRICTORS / Pages 60–69

- Can be used with fluids or gases
- Stainless steel design is standard
- Orifices can be calculated to achieve desired flow rates
- Threaded style can easily be changed out to alter flow rates
- Expansion style are tamper resistant

SPECIAL ORDERS / PAGE 71

SETTING TOOL EQUIPMENT / PAGES 72–79

SFC KOENIG® offers a variety of setting tools and equipment to assist in the installation of our parts.

- EXPRESS 3000 - Hydropneumatic Table Presses
- EXPRESS 5000 - Hydropneumatic Table Presses
- EXTTOOLS 030, 040-1 and 040-2
- KW-008 - Hand Lever Tool with Equipment Ø 4 – 6 mm

SYSTEMS AND AUTOMATION SOLUTIONS / PAGES 80–81

TECHNICAL INFORMATION / PAGES 82–108

QUALITY ASSURANCE / PAGE 109



Full Line of Sealing & Flow Control Technologies

KOENIG EXPANDER®

Series MB / CV

Sealing Plugs for Operating Pressures up to 450 bar / 6500 psi

- Operating pressures up to 450 bar / 6500 psi
- Comprehensive range of products for \varnothing 3 – 22 mm, also available in inch version
- Corrosion-resistant version
- Available in aluminum
- Standard drilling manufacturing tolerance 0 / + 0.10 mm
- Swift and easy installation
- Purely mechanical sealing through anchorage system

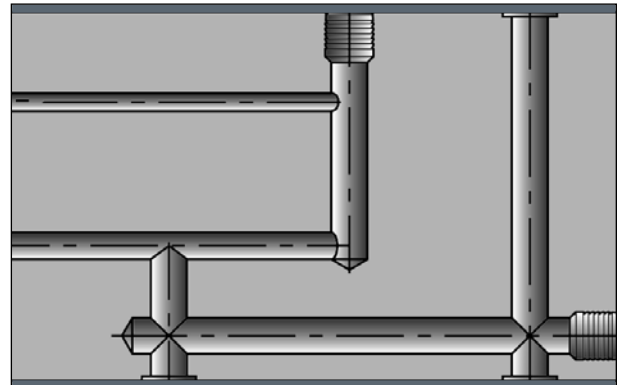
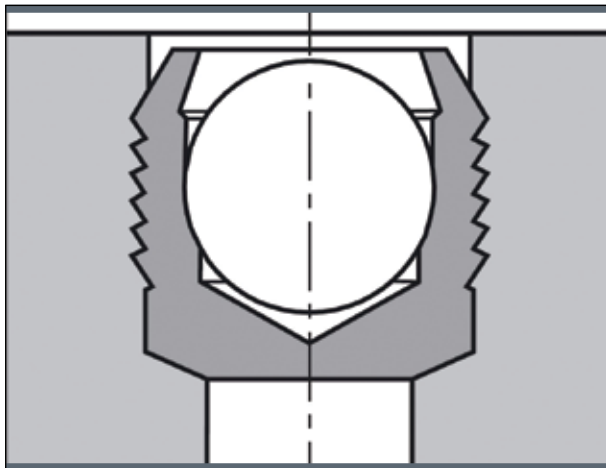

Please inquire with our sales or applications engineers about requirements for special materials or configurations not shown in the catalog.

RECOMMENDED SETTING EQUIPMENT FOR SERIES MB AND CV

EXPRESS 3000

Hydropneumatic Table Press

See page 74 for more information

EXPRESS 5000

Hydropneumatic Table Press

See page 74 for more information



KOENIG EXPANDER® SEALING PLUGS Series MB 600

Sleeve and Ball Clear Passivated per MIL-S-5002, Aerospace Quality

3D DATA: www.sfckoenig.com

Part Number	Order Number	d ₁	l ₁	(l ₂) ~ Ref.	d ₂ +0.1 0	d ₃ max	l ₃ min.	x ±0.2	Packaging Unit	Weight in gram/pcs.
MB 600-030	300110685	3.0	3.6	4.6	3.0	2.2	3.4	0.4	100 / 1000	0.17
MB 600-040	300110686	4.0	4.0	5.1	4.0	3.3	3.8	0.2	100 / 1000	0.34
MB 600-050	300110687	5.0	5.5	7.1	5.0	4.3	5.3	0.4	100 / 1000	0.68
MB 600-060	300110688	6.0	6.5	8.6	6.0	5.3	6.3	0.4	100 / 500	1.18
MB 600-070	300110689	7.0	7.5	10.1	7.0	6.4	7.3	0.4	100 / 250	1.91
MB 600-080	300110690	8.0	8.5	11.6	8.0	7.4	8.3	0.3	50 / 250	2.86
MB 600-090	300110691	9.0	10.0	13.5	9.0	8.4	9.8	0.4	50 / 250	4.02
MB 600-100	300110692	10.0	11.0	15.1	10.0	9.4	10.8	0.4	50 / 250	5.50
MB 600-120	300110693	12.0	13.0	17.8	12.0	10.6	12.8	0.4	25 / 100	9.37
MB 600-140	300110694	14.0	15.0	20.5	14.0	12.7	14.5	0.4	25 / 100	14.81

Dimensions in millimeters

PRESSURE PERFORMANCE

Series MB 600 mm	Base Material of the Installation						
	① ETG-100 / 44SMn28 AISI 1144	② C15Pb 1.0403	③ EN-GJL-250 EN 1561	④ EN-GJS-500-7 EN 1563	⑤ AlCu4Mg1 EN AW-2024-T3	⑥ AlMgSiPb EN AW-6012-T6	⑦ G-AlSi7Mg EN AC-42100
ø 3 – 10	1400 bar / 20300 psi 450 bar / 6500 psi					1200 bar / 17400 psi 380 bar / 5500 psi	
ø 12 – 14	1000 bar / 14500 psi 350 bar / 5100 psi					900 bar / 13000 psi 280 bar / 4100 psi	

Proof Pressure Test - (B)

Max. Allowable Working Pressure = Nominal Pressure

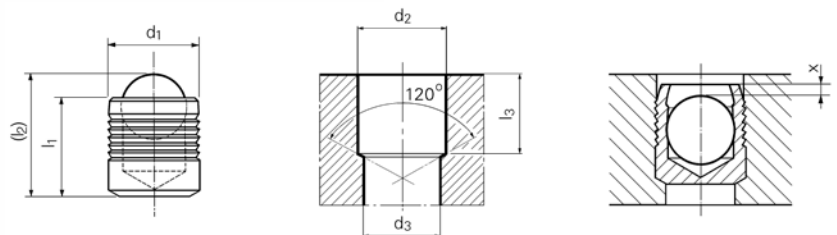

Material:

Sleeve: Stainless Steel 1.4305

Ball: Stainless Steel 1.4301

Important:

See installation instructions on pages 90-91

Installation requirements on page 85



KOENIG EXPANDER® SEALING PLUGS Series MB 600 Inch

Sleeve and Ball Clear Passivated per MIL-S-5002, Aerospace Quality

3D DATA: www.sfckoenig.com

Part Number	Order Number	d ₁	l ₁	(l ₂) ~ Ref.	d ₂	d ₃ max	l ₃ min.	x 0 -0.012	Packaging Unit	Weight in gram/pcs.
MB600-093A	300116822	0.093	0.100	0.120	0.0937	0.062	0.095	0.012	100 / 1000	0.07
MB600-125A	300116823	0.124	0.138	0.172	0.1250	0.093	0.125	0.012	100 / 1000	0.17
MB600-156A	300116826	0.156	0.150	0.196	0.1562	0.125	0.130	0.012	100 / 1000	0.31
MB600-187A	300116827	0.187	0.193	0.259	0.1875	0.156	0.152	0.012	100 / 500	0.53
MB600-218A	300116828	0.218	0.225	0.301	0.2187	0.187	0.187	0.012	100 / 500	0.86
MB600-250A	300116830	0.249	0.260	0.352	0.2500	0.218	0.212	0.012	100 / 500	1.26
MB600-281A	300116831	0.281	0.285	0.380	0.2812	0.250	0.250	0.012	100 / 500	1.87

Dimensions in inches

PRESSURE PERFORMANCE

Series MB 600 Inch	Base Material of the Installation						
	① ETG-100 / 44SMn28 AISI 1144	② C15Pb 1.0403	③ EN-GJL-250 EN 1561	④ EN-GJS-500-7 EN 1563	⑤ AlCu4Mg1 EN AW-2024-T3	⑥ AlMgSiPb EN AW-6012-T6	⑦ G-AlSi7Mg EN AC-42100
ø 0.093 – 0.281	1400 bar / 20300 psi 450 bar / 6500 psi					1200 bar / 17400 psi 380 bar / 5500 psi	

Proof Pressure Test - ⑥

Max. Allowable Working Pressure = Nominal Pressure

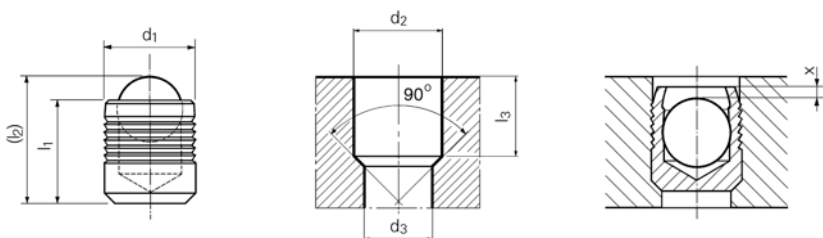

Toleranzen / Tolérances d₂: MB 600-093A = $+\frac{0.002}{0}$
MB 600-125A bis/à MB 600-281A = $+\frac{0.004}{0}$

Material:

Sleeve: Stainless Steel 1.4305

Ball: Stainless Steel 1.4301 (1.4034 MB 600-093)

Important:

See installation instructions on pages 90–91

Installation requirements on page 85



KOENIG EXPANDER® SEALING PLUGS Series MB 700

3D DATA: www.sfckoenig.com

Part Number	Order Number	d ₁	l ₁	(l ₂) ~ Ref.	d ₂ +0.1 0	d ₃ max	l ₃ min.	x ±0.2	Packaging Unit	Weight in gram/pcs.
MB 700-030	300110703	3.0	3.6	4.6	3.0	2.2	3.4	0.4	100 / 1000	0.17
MB 700-040	300110704	4.0	4.0	5.2	4.0	3.3	3.8	0.2	100 / 2000	0.34
MB 700-050	300110708	5.0	5.5	7.0	5.0	4.3	5.3	0.4	100 / 2000	0.68
MB 700-060	300110711	6.0	6.5	8.6	6.0	5.3	6.3	0.4	100 / 2000	1.17
MB 700-070	300110714	7.0	7.5	10.1	7.0	6.4	7.3	0.4	100 / 1000	1.90
MB 700-080	300110716	8.0	8.5	11.6	8.0	7.4	8.3	0.3	50 / 1000	2.84
MB 700-090	300110717	9.0	10.0	13.5	9.0	8.4	9.8	0.4	50 / 500	4.00
MB 700-100	300110719	10.0	11.0	15.1	10.0	9.4	10.8	0.4	50 / 500	5.47
MB 700-120	300110720	12.0	13.0	17.8	12.0	10.6	12.8	0.4	50 / 250	9.31
MB 700-140	300110721	14.0	15.0	20.4	14.0	12.7	14.5	0.4	50 / 250	14.72
MB 700-160	300110722	16.0	17.0	23.4	16.0	14.7	16.5	0.6	25 / 100	22.00
MB 700-180	300110724	18.0	19.0	26.3	18.0	16.7	18.5	0.6	25 / 100	31.34
MB 700-200	300110725	20.0	22.0	30.0	20.0	18.7	21.5	0.8	25 / 100	44.24
MB 700-220	300110726	22.0	25.0	34.0	22.0	20.7	24.5	0.8	25 / 50	58.61

Dimensions in millimeters

PRESSURE PERFORMANCE

Series MB 700 mm	Base Material of the Installation						
	① ETG-100 / 44SMn28 AISI 1144	② C15Pb 1.0403	③ EN-GJL-250 EN 1561	④ EN-GJS-500-7 EN 1563	⑤ AlCu4Mg1 EN AW-2024-T3	⑥ AlMgSiPb EN AW-6012-T6	⑦ G-AlSi7Mg EN AC-42100
Ø 3 – 10	1400 bar / 20300 psi 450 bar / 6500 psi					1200 bar / 17400 psi 380 bar / 5500 psi	
Ø 12 – 22	1000 bar / 16700 psi 350 bar / 5100 psi					900 bar / 13000 psi 280 bar / 4100 psi	

Proof Pressure Test - (B)

Max. Allowable Working Pressure = Nominal Pressure

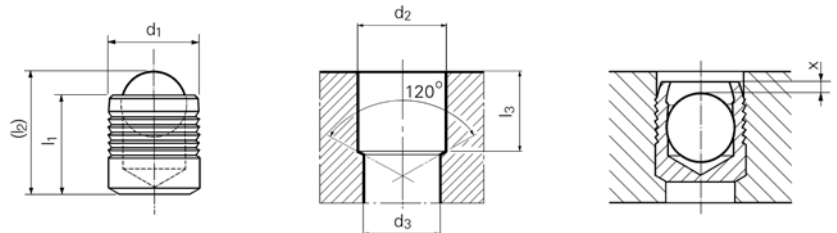

Material:

Sleeve: Stainless Steel DIN 1.4305

Ball: Bearing Steel, Heat Treated

Important:

See installation instructions on pages 90–91

Installation requirements on page 85



KOENIG EXPANDER® SEALING PLUGS Series MB 850

3D DATA: www.sfckoenig.com

Part Number	Order Number	d ₁	l ₁	(l ₂) ~ Ref.	d ₂ +0.1 0	d ₃ max	l ₃ min.	x ±0.2	Packaging Unit	Weight in gram/pcs.
MB 850-030	300135417	3.0	3.6	4.6	3.0	2.2	3.4	0.4	100 / 1000	0.17
MB 850-040	300135419	4.0	4.0	5.2	4.0	3.3	3.8	0.2	100 / 2000	0.34
MB 850-050	300133461	5.0	5.5	7.1	5.0	4.3	5.3	0.4	100 / 2000	0.68
MB 850-060	300135431	6.0	6.5	8.6	6.0	5.3	6.3	0.4	100 / 2000	1.17
MB 850-070	300135434	7.0	7.5	10.1	7.0	6.4	7.3	0.4	100 / 1000	1.91
MB 850-080	300135436	8.0	8.5	11.6	8.0	7.4	8.3	0.3	50 / 1000	2.84
MB 850-090	300133415	9.0	10.0	13.6	9.0	8.4	9.8	0.4	50 / 500	4.00
MB 850-100	300135440	10.0	11.0	15.1	10.0	9.4	10.8	0.4	50 / 500	5.47
MB 850-120	300135442	12.0	13.0	17.9	12.0	10.6	12.8	0.4	50 / 250	9.31
MB 850-140	300135444	14.0	15.0	20.6	14.0	12.7	14.5	0.4	50 / 250	14.72
MB 850-160	300135446	16.0	17.0	23.4	16.0	14.7	16.5	0.6	25 / 100	22.00
MB 850-180	300135448	18.0	19.0	26.4	18.0	16.7	18.5	0.6	25 / 100	31.34
MB 850-200	300135450	20.0	22.0	30.1	20.0	18.7	21.5	0.8	25 / 100	44.24
MB 850-220	300135452	22.0	25.0	34.0	22.0	20.7	24.5	0.8	25 / 50	58.61

Dimensions in millimeters

PRESSURE PERFORMANCE

Series MB 850 mm	Base Material of the Installation						
	① ETG-100 / 44SMn28 AISI 1144	② C15Pb 1.0403	③ EN-GJL-250 EN 1561	④ EN-GJS-500-7 EN 1563	⑤ AlCu4Mg1 EN AW-2024-T3	⑥ AlMgSiPb EN AW-6012-T6	⑦ G-AlSi7Mg EN AC-42100
Ø 3 – 10	1100 bar / 16000 psi 350 bar / 5100 psi					1000 bar / 14500 psi 320 bar / 4600 psi	
Ø 12 – 22	900 bar / 13000 psi 280 bar / 4100 psi					800 bar / 11600 psi 250 bar / 3600 psi	

Proof Pressure Test - (B)

Max. Allowable Working Pressure = Nominal Pressure

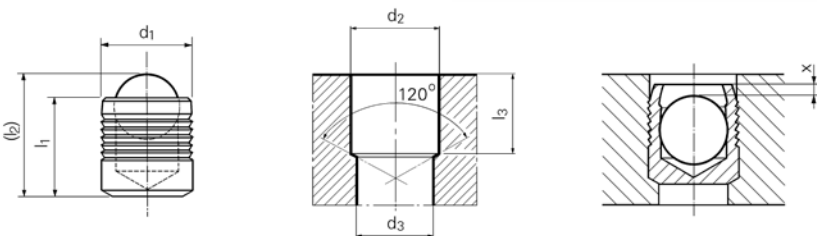

Material:

Sleeve: Case Hardening Steel Zinc Plated, Thick Coat Passivated, CR (VI)-Free
Ball: Bearing Steel, Heat Treated

Important:

See installation instructions on pages 90–91
Installation requirements on page 85



KOENIG EXPANDER® SETTING TOOLS Series MB

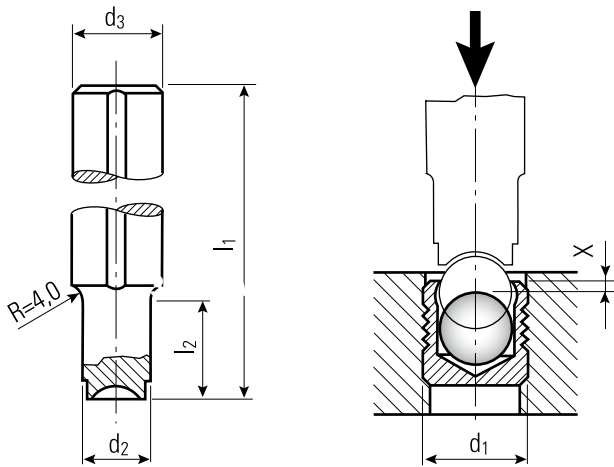

3D DATA: www.sfckoenig.com

Part Number	Order Number	d ₁ Expander	d ₃ -h9	l ₁	d ₂	l ₂	x ±0.2	Weight in gram/pcs.
MB 030	300110810	3.0	10	100	2.8	10	0.4	55
MB 040	300110811	4.0	10	100	3.8	10	0.2	55
MB 050	300110812	5.0	10	100	4.8	12	0.4	55
MB 060	300110813	6.0	10	100	5.8	15	0.4	55
MB 070	300110814	7.0	10	100	6.8	18	0.4	55
MB 080	300110815	8.0	10	100	7.8	20	0.3	55
MB 090	300110816	9.0	14	100	8.8	22	0.4	120
MB 100	300110817	10.0	14	100	9.8	25	0.4	120
MB 120	300110818	12.0	14	150	11.7	30	0.4	180
MB 140	300110819	14.0	20	150	13.7	35	0.4	350
MB 160	300110820	16.0	20	150	15.7	40	0.6	350
MB 180	300110821	18.0	20	150	17.7	45	0.6	350
MB 200	300110822	20.0	25	150	19.7	50	0.8	550
MB 220	300110823	22.0	25	150	21.7	55	0.8	550

Dimensions in millimeters

North American customers please refer to page 34

Material:

Tool Steel, Heat Treated, Hardness Approx. HRC 50

RECOMMENDED SETTING EQUIPMENT FOR SERIES MB

EXPRESS 3000	Hydropneumatic Table Press	See page 74 for more information
EXPRESS 5000	Hydropneumatic Table Press	See page 74 for more information

KOENIG EXPANDER® SETTING TOOLS Series MB Inch

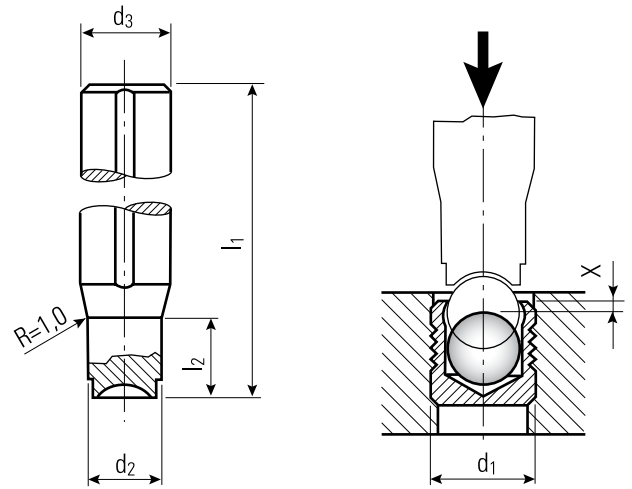

3D DATA: www.sfckoenig.com

Part Number	Order Number	d ₁ Expander	d ₃ -h9	l ₁	d ₂	l ₂	x 0 -0.012	Weight in gram/pcs.
MB 093A	300110781	0.093	0.394	3.94	0.082	0.137	0.012	55
MB 125A	300110782	0.125	0.394	3.94	0.117	0.137	0.012	55
MB 156A	300110783	0.156	0.394	3.94	0.148	0.137	0.012	55
MB 187A	300110784	0.187	0.394	3.94	0.180	0.137	0.012	55
MB 218A	300110785	0.218	0.394	3.94	0.211	0.400	0.012	55
MB 250A	300110786	0.250	0.394	3.94	0.242	0.400	0.012	55
MB 281A	300110787	0.281	0.394	3.94	0.273	0.400	0.012	55

Dimensions in inches

North American customers please refer to page 36

Material:

Tool Steel, Heat Treated, Hardness Approx. HRC 50

RECOMMENDED SETTING EQUIPMENT FOR SERIES MB

EXPRESS 3000	Hydropneumatic Table Press	See page 74 for more information
EXPRESS 5000	Hydropneumatic Table Press	See page 74 for more information

KOENIG EXPANDER® SEALING PLUGS Series CV 143

3D DATA: www.sfckoenig.com

Part Number	Order Number	d ₁	l ₁	(l ₂) ~ Ref.	d ₂ +0.1 0	d ₃ max	l ₃ min.	x ±0.1	(s) ~ Ref.	Packaging Unit	Weight in gram/pcs.
CV 143-030	300169193	3.0	3.18	4.1	3.0	2.3	2.9	0.2	1.0	100 / 1000	0.09
CV 143-040	300169194	4.0	4.00	5.2	4.0	3.3	3.8	0.2	1.4	100 / 1000	0.20
CV 143-050	300169195	5.0	5.50	7.0	5.0	4.3	5.3	0.2	1.9	100 / 1000	0.44
CV 143-060	300169196	6.0	6.50	8.6	6.0	5.3	6.3	0.2	2.3	100 / 1000	0.78
CV 143-070	300169197	7.0	7.50	10.1	7.0	6.2	7.3	0.2	2.8	100 / 1000	1.28
CV 143-080	300169198	8.0	8.50	11.7	8.0	7.2	8.3	0.2	3.4	100 / 1000	1.96
CV 143-090	300169199	9.0	10.00	13.7	9.0	8.2	9.8	0.2	3.7	100 / 1000	2.88
CV 143-100	300169200	10.0	11.00	15.2	10.0	9.2	10.8	0.2	4.2	100 / 500	4.01
CV 143-120	300169201	12.0	13.00	18.0	12.0	11.0	12.8	0.2	5.1	50 / 250	7.06
CV 143-140	300169203	14.0	15.00	20.8	14.0	13.0	14.5	0.2	5.9	50 / 250	11.00
CV 143-160	300169206	16.0	17.00	23.7	16.0	14.7	16.5	0.2	6.4	50 / 100	15.65
CV 143-180	300169207	18.0	19.00	26.3	18.0	16.7	18.5	0.2	7.2	50 / 100	22.40
CV 143-200	300169211	20.0	22.00	30.5	20.0	18.7	21.5	0.2	8.4	50 / 100	32.26
CV 143-220	300169214	22.0	25.00	34.2	22.0	20.7	24.5	0.2	9.5	25 / 50	44.24

Dimensions in millimeters

Not all items in stock – production MOQ & lead times may apply

Performance data can be provided for specific applications upon request

PRESSURE PERFORMANCE

Series CV 143 mm	Base Material of the Installation				
	Al A356	Al 2024-T4	Cl 60-45-12	Cl GJS 600	Steel ETG-100
Ø 3 – 10		170 bar / 2500 psi			
Ø 12 – 22					
Hole	Tolerance	0 / + 0.1 mm			
	Roughness	Anchorage	R _Z 10 – 30 µm		

Max. Allowable Working Pressure = Nominal Pressure

Please note these recommendations are generally conservative and higher working pressures are possible in some applications. Please contact your local applications engineer with any questions.

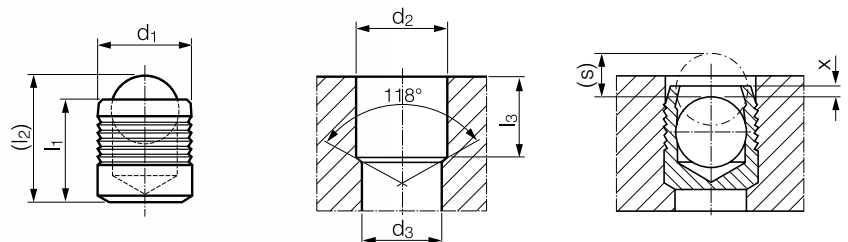

Material:

Sleeve: Aluminum 2024-T4, QQ-A 225/6, Anodized Green, MIL-A-8625:
Type II Class 2

Ball: Stainless Steel, AISI 302/304, Wax Film Lubrication (Diameter Dependant)

KOENIG EXPANDER® SEALING PLUGS Series CV 163

3D DATA: www.sfckoenig.com

Part Number	Order Number	d ₁	l ₁	(l ₂) ~ Ref.	d ₂ +0.1 0	d ₃ max	l ₃ min.	x ±0.1	(s) ~ Ref.	Packaging Unit	Weight in gram/pcs.
CV 163-030	300169234	3.0	3.18	4.1	3.0	2.3	2.9	0.2	1.0	100 / 1000	0.09
CV 163-040	300169653	4.0	4.00	5.2	4.0	3.3	3.8	0.2	1.4	100 / 1000	0.20
CV 163-050	300169235	5.0	5.50	7.0	5.0	4.3	5.3	0.2	1.9	100 / 1000	0.44
CV 163-060	300169236	6.0	6.50	8.6	6.0	5.3	6.3	0.2	2.3	100 / 1000	0.78
CV 163-070	300169237	7.0	7.50	10.1	7.0	6.2	7.3	0.2	2.8	100 / 1000	1.28
CV 163-080	300169238	8.0	8.50	11.7	8.0	7.2	8.3	0.2	3.4	100 / 1000	1.96
CV 163-090	300169239	9.0	10.00	13.7	9.0	8.2	9.8	0.2	3.7	100 / 1000	2.88
CV 163-100	300169240	10.0	11.00	15.2	10.0	9.2	10.8	0.2	4.2	100 / 500	4.01
CV 163-120	300169241	12.0	13.00	18.0	12.0	11.0	12.8	0.2	5.1	50 / 250	7.06
CV 163-140	300169243	14.0	15.00	20.8	14.0	13.0	14.5	0.2	5.9	50 / 250	11.00
CV 163-160	300169246	16.0	17.00	23.7	16.0	14.7	16.5	0.2	6.4	50 / 100	15.65
CV 163-180	300169247	18.0	19.00	26.3	18.0	16.7	18.5	0.2	7.2	50 / 100	22.40
CV 163-200	300169250	20.0	22.00	30.5	20.0	18.7	21.5	0.2	8.4	50 / 100	32.26
CV 163-220	300169253	22.0	25.00	34.2	22.0	20.7	24.5	0.2	9.5	25 / 50	44.24

Dimensions in millimeters

Not all items in stock – production MOQ & lead times may apply

Performance data can be provided for specific applications upon request

PRESSURE PERFORMANCE

Series CV 163 mm	Base Material of the Installation				
	Al A356	Al 2024-T4	Cl 60-45-12	Cl GJS 600	Steel ETG-100
∅ 3 – 10		170 bar / 2500 psi			
∅ 12 – 22					
Hole	Tolerance	0 / + 0.1 mm			
	Roughness	Anchorage	R _z 10 – 30 µm		

Max. Allowable Working Pressure = Nominal Pressure

Please note these recommendations are generally conservative and higher working pressures are possible in some applications. Please contact your local applications engineer with any questions.

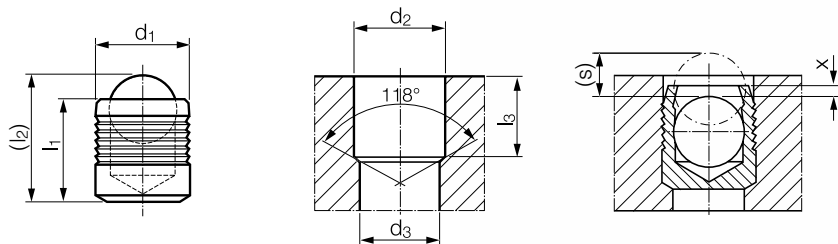

Material:

Sleeve: Aluminum 2024-T4, QQ-A 225/6, Allodined Chromate Conversion, MIL-C-5541

Ball: Stainless Steel, AISI 302/304, Wax Film Lubrication (Diameter Dependant)



KOENIG EXPANDER® SEALING PLUGS Series CV 173

3D DATA: www.sfckoenig.com

Part Number	Order Number	d ₁	l ₁	(l ₂) ~ Ref.	d ₂ +0.1 0	d ₃ max	l ₃ min.	x ±0.1	(s) ~ Ref.	Packaging Unit	Weight in gram/pcs.
CV 173-030	300169275	3.0	3.18	4.1	3.0	2.3	2.9	0.2	1.0	100 / 1000	0.09
CV 173-040	300169276	4.0	4.00	5.2	4.0	3.3	3.8	0.2	1.4	100 / 1000	0.20
CV 173-050	300169277	5.0	5.50	7.0	5.0	4.3	5.3	0.2	1.9	100 / 1000	0.44
CV 173-060	300169278	6.0	6.50	8.6	6.0	5.3	6.3	0.2	2.3	100 / 1000	0.78
CV 173-070	300169279	7.0	7.50	10.1	7.0	6.2	7.3	0.2	2.8	100 / 1000	1.28
CV 173-080	300169280	8.0	8.50	11.7	8.0	7.2	8.3	0.2	3.4	100 / 1000	1.96
CV 173-090	300169281	9.0	10.00	13.7	9.0	8.2	9.8	0.2	3.7	100 / 1000	2.88
CV 173-100	300169282	10.0	11.00	15.2	10.0	9.2	10.8	0.2	4.2	100 / 500	4.01
CV 173-120	300169283	12.0	13.00	18.0	12.0	11.0	12.8	0.2	5.1	50 / 250	7.06
CV 173-140	300169285	14.0	15.00	20.8	14.0	13.0	14.5	0.2	5.9	50 / 250	11.00
CV 173-160	300169288	16.0	17.00	23.7	16.0	14.7	16.5	0.2	6.4	25 / 100	15.65
CV 173-180	300169272	18.0	19.00	26.3	18.0	16.7	18.5	0.2	7.2	25 / 100	22.40
CV 173-200	300169273	20.0	22.00	30.5	20.0	18.7	21.5	0.2	8.4	25 / 100	32.26
CV 173-220	300169274	22.0	25.00	34.2	22.0	20.7	24.5	0.2	9.5	25 / 50	44.24

Dimensions in millimeters

Not all items in stock – production MOQ & lead times may apply

Performance data can be provided for specific applications upon request

PRESSURE PERFORMANCE

Series CV 173 mm	Base Material of the Installation				
	Al A356	Al 2024-T4	CI 60-45-12	CI GJS 600	Steel ETG-100
ø 3 – 10		170 bar / 2500 psi			
ø 12 – 22					
Hole	Tolerance	0 / + 0.1 mm			
	Roughness	Anchorage	R _Z 10 – 30 µm		

Max. Allowable Working Pressure = Nominal Pressure

Please note these recommendations are generally conservative and higher working pressures are possible in some applications. Please contact your local applications engineer with any questions.

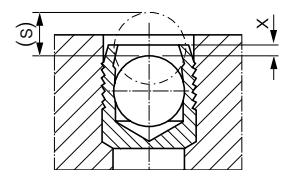
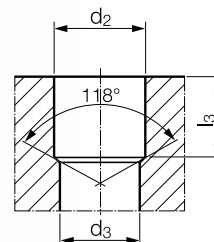
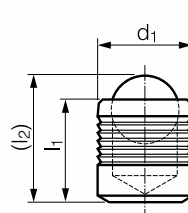

Material:

Sleeve: Aluminum 2024-T4, QQ-A 225/6

Ball: Stainless Steel, AISI 302/304, Wax Film Lubrication (Diameter Dependant)

KOENIG EXPANDER® SEALING PLUGS Series CV 588

3D DATA: www.sfckoenig.com

Part Number	Order Number	d ₁	l ₁	(l ₂) ~ Ref.	d ₂ +0.1 0	d ₃ max	l ₃ min.	x ±0.1	(s) ~ Ref.	Packaging Unit	Weight in gram/pcs.
CV 588-030	300169493	3.0	3.18	4.1	3.0	2.3	2.9	0.2	1.0	100 / 1000	0.16
CV 588-040	300169494	4.0	4.00	5.2	4.0	3.3	3.8	0.2	1.4	100 / 1000	0.36
CV 588-050	300169495	5.0	5.50	7.0	5.0	4.3	5.3	0.2	1.9	100 / 1000	0.76
CV 588-060	300169496	6.0	6.50	8.6	6.0	5.3	6.3	0.2	2.3	100 / 1000	1.28
CV 588-070	300169497	7.0	7.50	10.1	7.0	6.2	7.3	0.2	2.8	100 / 1000	2.00
CV 588-080	300169498	8.0	8.50	11.7	8.0	7.2	8.3	0.2	3.4	100 / 1000	2.96
CV 588-090	300169499	9.0	10.00	13.7	9.0	8.2	9.8	0.2	3.7	100 / 1000	4.31
CV 588-100	300169500	10.0	11.00	15.2	10.0	9.2	10.8	0.2	4.2	100 / 500	5.88
CV 588-120	300169501	12.0	13.00	18.0	12.0	11.0	12.8	0.2	5.1	50 / 250	9.99
CV 588-140	300169503	14.0	15.00	20.8	14.0	13.0	14.5	0.2	5.9	50 / 250	15.77
CV 588-160	300169506	16.0	17.00	23.7	16.0	14.7	16.5	0.2	6.4	25 / 100	23.73
CV 588-180	300169507	18.0	19.00	26.3	18.0	16.7	18.5	0.2	7.2	25 / 100	33.42
CV 588-200	300169511	20.0	22.00	30.5	20.0	18.7	21.5	0.2	8.4	25 / 100	47.58
CV 588-220	300169514	22.0	25.00	34.2	22.0	20.7	24.5	0.2	9.5	25 / 50	65.25

Dimensions in millimeters

Not all items in stock – production MOQ & lead times may apply

Performance data can be provided for specific applications upon request

PRESSURE PERFORMANCE

Series CV 588 mm	Base Material of the Installation				
	Al A356	Al 2024-T4	Cl 60-45-12	Cl GJS 600	Steel ETG-100
∅ 3 – 10	450 bar / 6500 psi				
∅ 12 – 22	450 bar / 6500 psi				
Hole	Tolerance	0 / + 0.1 mm			
	Roughness	Anchorage in Base Material			R _z 10 – 30 µm

Max. Allowable Working Pressure = Nominal Pressure

Please note these recommendations are generally conservative and higher working pressures are possible in some applications. Please contact your local applications engineer with any questions.

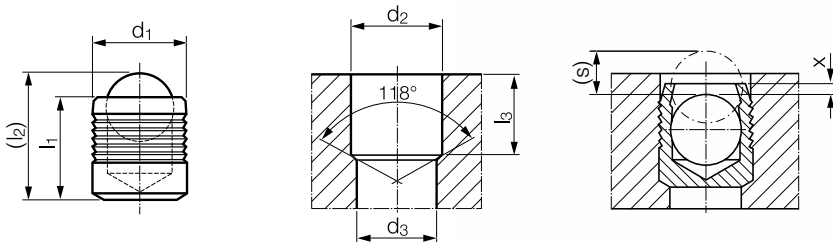

Material:

Sleeve: Stainless Steel [316] ASTM A580, Passivate, QQ-P-35C

Ball: Stainless Steel, AISI 316, Wax Film Lubrication [Diameter Dependant]



KOENIG EXPANDER® SEALING PLUGS Series CV 143 Inch

3D DATA: www.sfckoenig.com

Part Number	Order Number	d ₁	l ₁	(l ₂) ~ Ref.	d ₂ +0.004 0	d ₃ max.	l ₃ min.	x ±0.004	(s) ~ Ref.	Packaging Unit	Weight in gram/pcs.
CV 143-156	300169204	0.156	0.158	0.21	0.1562	0.130	0.149	0.008	0.053	100 / 1000	0.19
CV 143-187	300169208	0.187	0.217	0.27	0.1875	0.160	0.208	0.010	0.066	100 / 1000	0.37
CV 143-218	300169212	0.218	0.217	0.28	0.2187	0.190	0.208	0.010	0.078	100 / 1000	0.55
CV 143-250	300169215	0.250	0.256	0.34	0.2500	0.220	0.247	0.010	0.094	100 / 1000	0.87
CV 143-281	300169217	0.281	0.296	0.40	0.2812	0.250	0.287	0.010	0.110	100 / 1000	1.60
CV 143-312	300169219	0.312	0.335	0.46	0.3125	0.281	0.326	0.010	0.129	100 / 1000	1.93
CV 143-343	300169221	0.343	0.394	0.52	0.3437	0.312	0.385	0.010	0.140	100 / 500	2.58
CV 143-375	300169223	0.375	0.394	0.54	0.3750	0.343	0.385	0.010	0.153	100 / 500	3.25
CV 143-406	300169224	0.406	0.434	0.59	0.4062	0.375	0.425	0.010	0.162	100 / 500	4.16
CV 143-437	300169226	0.437	0.512	0.68	0.4375	0.406	0.503	0.010	0.166	50 / 250	5.70
CV 143-468	300169227	0.468	0.512	0.71	0.4687	0.437	0.503	0.010	0.199	50 / 250	6.95
CV 143-562	300169228	0.562	0.591	0.82	0.5625	0.510	0.570	0.010	0.233	50 / 250	11.37
CV 143-625	300169229	0.625	0.669	0.91	0.6250	0.562	0.649	0.010	0.252	50 / 100	15.50
CV 143-687	300169230	0.687	0.748	1.03	0.6875	0.625	0.727	0.010	0.289	50 / 100	21.61
CV 143-750	300169231	0.750	0.866	1.18	0.7500	0.688	0.845	0.010	0.317	50 / 100	29.06
CV 143-875	300169232	0.875	0.984	1.35	0.8750	0.813	0.963	0.010	0.354	25 / 50	44.79

Dimensions in inches

Not all items in stock – production MOQ & lead times may apply

Performance data can be provided for specific applications upon request

PRESSURE PERFORMANCE

Series CV 143 mm	Base Material of the Installation				
	Al A356	Al 2024-T4	CI 60-45-12	CI GJS 600	Steel ETG-100
ø 3 – 10		170 bar / 2500 psi			
ø 12 – 22					
Hole	Tolerance	0 / + 0.1 mm			
	Roughness	Anchorage	R _z 10 – 30 µm		

Max. Allowable Working Pressure = Nominal Pressure

Please note these recommendations are generally conservative and higher working pressures are possible in some applications. Please contact your local applications engineer with any questions.

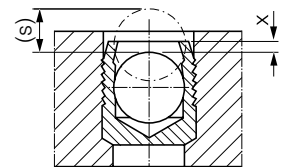
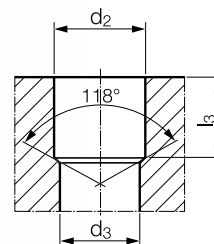
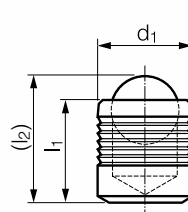

Material:

Sleeve: Aluminum 2024-T4, QQ-A 225/6, Anodized Green, MIL-A-8625:
Type II Class 2

Ball: Stainless Steel, AISI 302/304, Wax Film Lubrication (Diameter Dependant)

KOENIG EXPANDER® SEALING PLUGS Series CV 163 Inch

3D DATA: www.sfckoenig.com

Part Number	Order Number	d ₁	l ₁	(l ₂) ~ Ref.	d ₂ +0.004 0	d ₃ max.	l ₃ min.	x ±0.004	(s) ~ Ref.	Packaging Unit	Weight in gram/pcs.
CV 163-156	300169244	0.156	0.158	0.21	0.1562	0.130	0.149	0.008	0.053	100 / 1000	0.19
CV 163-187	300169248	0.187	0.217	0.27	0.1875	0.160	0.208	0.010	0.066	100 / 1000	0.37
CV 163-218	300169251	0.218	0.217	0.28	0.2187	0.190	0.208	0.010	0.078	100 / 1000	0.55
CV 163-250	300169254	0.250	0.256	0.34	0.2500	0.220	0.247	0.010	0.094	100 / 1000	0.87
CV 163-281	300169256	0.281	0.296	0.40	0.2812	0.250	0.287	0.010	0.110	100 / 1000	1.60
CV 163-312	300169258	0.312	0.335	0.46	0.3125	0.281	0.326	0.010	0.129	100 / 1000	1.93
CV 163-343	300169260	0.343	0.394	0.52	0.3437	0.312	0.385	0.010	0.140	100 / 500	2.58
CV 163-375	300169262	0.375	0.394	0.54	0.3750	0.343	0.385	0.010	0.153	100 / 500	3.25
CV 163-406	300169263	0.406	0.434	0.59	0.4062	0.375	0.425	0.010	0.162	100 / 500	4.16
CV 163-437	300169265	0.437	0.512	0.68	0.4375	0.406	0.503	0.010	0.166	50 / 250	5.70
CV 163-468	300169266	0.468	0.512	0.71	0.4687	0.437	0.503	0.010	0.199	50 / 250	6.95
CV 163-562	300169267	0.562	0.591	0.82	0.5625	0.510	0.570	0.010	0.233	50 / 250	11.37
CV 163-625	300169268	0.625	0.669	0.91	0.6250	0.562	0.649	0.010	0.252	50 / 100	15.50
CV 163-687	300169269	0.687	0.748	1.03	0.6875	0.625	0.727	0.010	0.289	50 / 100	21.61
CV 163-750	300169270	0.750	0.866	1.18	0.7500	0.688	0.845	0.010	0.317	25 / 100	29.06
CV 163-875	300169271	0.875	0.984	1.35	0.8750	0.813	0.963	0.010	0.354	25 / 50	44.79

Dimensions in inches

Not all items in stock – production MOQ & lead times may apply

Performance data can be provided for specific applications upon request

PRESSURE PERFORMANCE

Series CV 163 mm	Base Material of the Installation				
	Al A356	Al 2024-T4	Cl 60-45-12	Cl GJS 600	Steel ETG-100
ø 3 – 10		170 bar / 2500 psi			
ø 12 – 22					
Hole	Tolerance	0 / + 0.1 mm			
	Roughness	Anchorage	R _z 10 – 30 µm		

Max. Allowable Working Pressure = Nominal Pressure

Please note these recommendations are generally conservative and higher working pressures are possible in some applications. Please contact your local applications engineer with any questions.

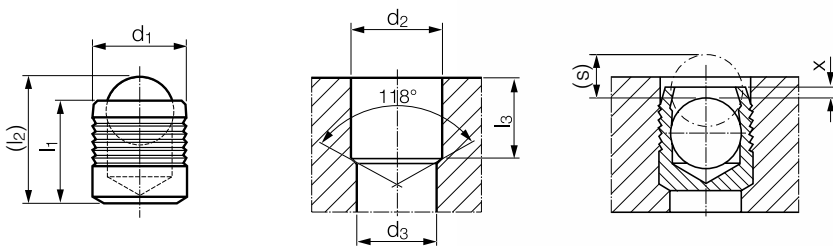

Material:

Sleeve: Aluminum 2024-T4, QQ-A 225/6, Allodined Chromate, MIL-C-5541

Ball: Stainless Steel, AISI 302/304, Wax Film Lubrication (Diameter Dependant)

KOENIG EXPANDER® SEALING PLUGS Series CV 173 Inch

3D DATA: www.sfckoenig.com

Part Number	Order Number	d ₁	l ₁	(l ₂) ~ Ref.	d ₂ +0.004 0	d ₃ max.	l ₃ min.	x ±0.004	(s) ~ Ref.	Packaging Unit	Weight in gram/pcs.
CV 173-156	300169286	0.156	0.158	0.21	0.1562	0.130	0.149	0.008	0.053	100 / 1000	0.19
CV 173-187	300169289	0.187	0.217	0.27	0.1875	0.160	0.208	0.010	0.066	100 / 1000	0.37
CV 173-218	300169291	0.218	0.217	0.28	0.2187	0.190	0.208	0.010	0.078	100 / 1000	0.55
CV 173-250	300169293	0.250	0.256	0.34	0.2500	0.220	0.247	0.010	0.094	100 / 1000	0.87
CV 173-281	300169295	0.281	0.296	0.40	0.2812	0.250	0.287	0.010	0.110	100 / 1000	1.60
CV 173-312	300169297	0.312	0.335	0.46	0.3125	0.281	0.326	0.010	0.129	100 / 1000	1.93
CV 173-343	300169299	0.343	0.394	0.52	0.3437	0.312	0.385	0.010	0.140	100 / 500	2.58
CV 173-375	300169301	0.375	0.394	0.54	0.3750	0.343	0.385	0.010	0.153	100 / 500	3.25
CV 173-406	300169302	0.406	0.434	0.59	0.4062	0.375	0.425	0.010	0.162	100 / 500	4.20
CV 173-437	300169304	0.437	0.512	0.68	0.4375	0.406	0.503	0.010	0.166	50 / 250	5.70
CV 173-468	300169305	0.468	0.512	0.71	0.4687	0.437	0.503	0.010	0.199	50 / 250	6.95
CV 173-562	300169306	0.562	0.591	0.82	0.5625	0.510	0.570	0.010	0.233	50 / 250	11.37
CV 173-625	300169307	0.625	0.669	0.91	0.6250	0.562	0.649	0.010	0.252	25 / 100	15.50
CV 173-687	300169308	0.687	0.748	1.03	0.6875	0.625	0.727	0.010	0.289	25 / 100	21.61
CV 173-750	300169309	0.750	0.866	1.18	0.7500	0.688	0.845	0.010	0.317	25 / 100	29.06
CV 173-875	300169310	0.875	0.984	1.35	0.8750	0.813	0.963	0.010	0.354	25 / 50	44.79

Dimensions in inches

Not all items in stock – production MOQ & lead times may apply

Performance data can be provided for specific applications upon request

PRESSURE PERFORMANCE

Series CV 173 Inch	Base Material of the Installation				
	Al A356	Al 2024-T4	Cl 60-45-12	Cl GJS 600	Steel ETG-100
Ø 0.156 – 0.375		170 bar / 2500 psi			
Ø 0.406 – 0.875					
Hole	Tolerance	0 / + 0.004 in			
	Roughness	Anchorage	R _z 10 – 30 µm		

Max. Allowable Working Pressure = Nominal Pressure

Please note these recommendations are generally conservative and higher working pressures are possible in some applications. Please contact your local applications engineer with any questions.

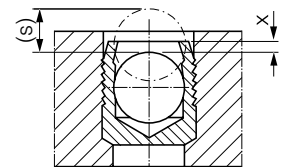
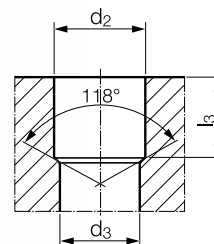
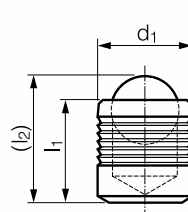

Material:

Sleeve: Aluminum 2024-T4, QQ-A 225/6

Ball: Stainless Steel, AISI 302/304, Wax Film Lubrication (Diameter Dependant)

KOENIG EXPANDER® SEALING PLUGS Series CV 531 Inch

3D DATA: www.sfckoenig.com

Part Number	Order Number	d ₁	l ₁	(l ₂) ~ Ref.	d ₂ +0.004 0	d ₃ max.	l ₃ min.	x ±0.004	(s) ~ Ref.	Packaging Unit	Weight in gram/pcs.
CV 531-156	300169352	0.156	0.158	0.21	0.1562	0.130	0.149	0.008	0.053	100 / 1000	0.35
CV 531-187	300169354	0.187	0.217	0.27	0.1875	0.160	0.208	0.010	0.066	100 / 1000	0.70
CV 531-218	300169356	0.218	0.217	0.28	0.2187	0.190	0.208	0.010	0.078	100 / 1000	0.93
CV 531-250	300169358	0.250	0.256	0.34	0.2500	0.220	0.247	0.010	0.094	100 / 1000	1.41
CV 531-281	300169360	0.281	0.296	0.40	0.2812	0.250	0.287	0.010	0.110	100 / 1000	2.91
CV 531-312	300169362	0.312	0.335	0.46	0.3125	0.281	0.326	0.010	0.129	100 / 1000	2.85
CV 531-343	-	0.343	0.394	0.52	0.3437	0.312	0.385	0.010	0.140	100 / 500	4.07
CV 531-375	300169365	0.375	0.394	0.54	0.3750	0.343	0.385	0.010	0.153	100 / 500	4.81
CV 531-406	300169366	0.406	0.434	0.59	0.4062	0.375	0.425	0.010	0.162	100 / 500	6.26
CV 531-437	300167914	0.437	0.512	0.68	0.4375	0.406	0.503	0.010	0.166	50 / 250	8.56
CV 531-468	-	0.468	0.512	0.71	0.4687	0.437	0.503	0.010	0.199	50 / 250	9.57
CV 531-562	300169367	0.562	0.591	0.82	0.5625	0.510	0.570	0.010	0.233	50 / 250	15.51
CV 531-625	300169368	0.625	0.669	0.91	0.6250	0.562	0.649	0.010	0.252	25 / 100	23.08
CV 531-687	300170192	0.687	0.748	1.03	0.6875	0.625	0.727	0.010	0.289	25 / 100	30.82
CV 531-750	300169369	0.750	0.866	1.18	0.7500	0.688	0.845	0.010	0.317	25 / 100	41.90
CV 531-875	-	0.875	0.984	1.35	0.8750	0.813	0.963	0.010	0.354	25 / 50	66.17

Dimensions in inches

Not all items in stock – production MOQ & lead times may apply

Performance data can be provided for specific applications upon request

PRESSURE PERFORMANCE

Series CV 531 Inch	Base Material of the Installation				
	Al A356	Al 2024-T4	CI 60-45-12	CI GJS 600	Steel ETG-100
Ø 0.156 – 0.375	450 bar / 6500 psi				
Ø 0.406 – 0.875	450 bar / 6500 psi				
Hole	Tolerance	0 / + 0.004 in			
	Roughness	Anchorage in Base Material			R _z 10 – 30 µm

Max. Allowable Working Pressure = Nominal Pressure

Please note these recommendations are generally conservative and higher working pressures are possible in some applications. Please contact your local applications engineer with any questions.

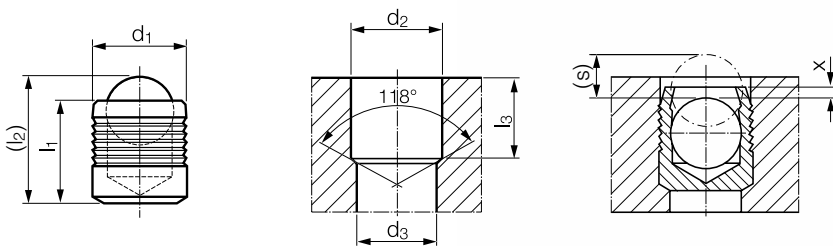

Material:

Sleeve: Stainless Steel [303] ASTM A582

Ball: Bearing Steel, Heat Treated, Black Oxide + Wax Film

Lubrication (Diameter Dependant)



KOENIG EXPANDER® SEALING PLUGS Series CV 533 Inch

3D DATA: www.sfckoenig.com

Part Number	Order Number	d ₁	l ₁	(l ₂) ~ Ref.	d ₂ +0.004 0	d ₃ max.	l ₃ min.	x ±0.004	(s) ~ Ref.	Packaging Unit	Weight in gram/pcs.
CV 533-156	300169383	0.156	0.158	0.21	0.1562	0.130	0.149	0.008	0.053	100 / 1000	0.35
CV 533-187	300169385	0.187	0.217	0.27	0.1875	0.160	0.208	0.010	0.066	100 / 1000	0.70
CV 533-218	300169387	0.218	0.217	0.28	0.2187	0.190	0.208	0.010	0.078	100 / 1000	0.94
CV 533-250	300169389	0.250	0.256	0.34	0.2500	0.220	0.247	0.010	0.094	100 / 1000	1.42
CV 533-281	300169391	0.281	0.296	0.40	0.2812	0.250	0.287	0.010	0.110	100 / 1000	2.91
CV 533-312	300169393	0.312	0.335	0.46	0.3125	0.281	0.326	0.010	0.129	100 / 1000	2.86
CV 533-343	300169395	0.343	0.394	0.52	0.3437	0.312	0.385	0.010	0.140	100 / 500	4.09
CV 533-375	300169397	0.375	0.394	0.54	0.3750	0.343	0.385	0.010	0.153	100 / 500	4.83
CV 533-406	300169398	0.406	0.434	0.59	0.4062	0.375	0.425	0.010	0.162	100 / 500	6.28
CV 533-437	300169400	0.437	0.512	0.68	0.4375	0.406	0.503	0.010	0.166	50 / 250	8.80
CV 533-468	300169401	0.468	0.512	0.71	0.4687	0.437	0.503	0.010	0.199	50 / 250	9.62
CV 533-562	300170025	0.562	0.591	0.82	0.5625	0.510	0.570	0.010	0.233	50 / 250	15.59
CV 533-625	300170248	0.625	0.669	0.91	0.6250	0.562	0.649	0.010	0.252	50 / 100	23.18
CV 533-687	300170192	0.687	0.748	1.03	0.6875	0.625	0.727	0.010	0.289	25 / 100	30.97
CV 533-750	-	0.750	0.866	1.18	0.7500	0.688	0.845	0.010	0.317	50 / 100	42.09
CV 533-875	300170046	0.875	0.984	1.35	0.8750	0.813	0.963	0.010	0.354	25 / 50	66.46

Dimensions in inches

Not all items in stock – production MOQ & lead times may apply

Performance data can be provided for specific applications upon request

PRESSURE PERFORMANCE

Series CV 533 Inch	Base Material of the Installation				
	Al A356	Al 2024-T4	Cl 60-45-12	Cl GJS 600	Steel ETG-100
Ø 0.156 – 0.375	450 bar / 6500 psi				
Ø 0.406 – 0.875	450 bar / 6500 psi				
Hole	Tolerance	0 / + 0.004 in			
	Roughness	Anchorage in Base Material			R _z 10 – 30 µm

Max. Allowable Working Pressure = Nominal Pressure

Please note these recommendations are generally conservative and higher working pressures are possible in some applications. Please contact your local applications engineer with any questions.

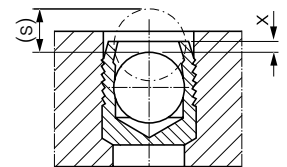
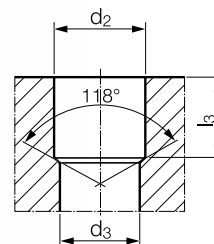
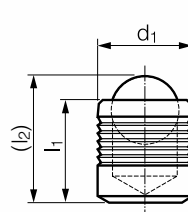

Material:

Sleeve: Stainless Steel [303] ASTM A582

Ball: Stainless Steel, AISI 302/304, Wax Film Lubrication (Diameter Dependant)

KOENIG EXPANDER® SEALING PLUGS Series CV 588 Inch

3D DATA: www.sfckoenig.com

Part Number	Order Number	d ₁	l ₁	(l ₂) ~ Ref.	d ₂ +0.004 0	d ₃ max.	l ₃ min.	x ±0.004	(s) ~ Ref.	Packaging Unit	Weight in gram/pcs.
CV 588-156	300169504	0.156	0.158	0.21	0.1562	0.130	0.149	0.008	0.053	500 / 1000	0.35
CV 588-187	300169687	0.187	0.217	0.27	0.1875	0.160	0.208	0.010	0.066	100 / 1000	0.71
CV 588-218	300169512	0.218	0.217	0.28	0.2187	0.190	0.208	0.010	0.078	100 / 1000	0.94
CV 588-250	300169689	0.250	0.256	0.34	0.2500	0.220	0.247	0.010	0.094	100 / 1000	1.42
CV 588-281	300169517	0.281	0.296	0.40	0.2812	0.250	0.287	0.010	0.110	100 / 1000	2.92
CV 588-312	300169519	0.312	0.335	0.46	0.3125	0.281	0.326	0.010	0.129	100 / 1000	3.88
CV 588-343	300169521	0.343	0.394	0.52	0.3437	0.312	0.385	0.010	0.140	100 / 500	4.11
CV 588-375	300169523	0.375	0.394	0.54	0.3750	0.343	0.385	0.010	0.153	100 / 500	4.86
CV 588-406	300169694	0.406	0.434	0.59	0.4062	0.375	0.425	0.010	0.162	100 / 500	6.31
CV 588-437	300169526	0.437	0.512	0.68	0.4375	0.406	0.503	0.010	0.166	50 / 250	8.64
CV 588-468	300169527	0.468	0.512	0.71	0.4687	0.437	0.503	0.010	0.199	50 / 250	9.68
CV 588-562	300169528	0.562	0.591	0.82	0.5625	0.510	0.570	0.010	0.233	50 / 250	15.68
CV 588-625	300169529	0.625	0.669	0.91	0.6250	0.562	0.649	0.010	0.252	25 / 100	23.30
CV 588-687	300169530	0.687	0.748	1.03	0.6875	0.625	0.727	0.010	0.289	25 / 100	31.14
CV 588-750	300169531	0.750	0.866	1.18	0.7500	0.688	0.845	0.010	0.317	25 / 100	42.32
CV 588-875	300169532	0.875	0.984	1.35	0.8750	0.813	0.963	0.010	0.354	25 / 50	66.80

Dimensions in inches

Not all items in stock – production MOQ & lead times may apply

Performance data can be provided for specific applications upon request

PRESSURE PERFORMANCE

Series CV 588 Inch	Base Material of the Installation				
	Al A356	Al 2024-T4	CI 60-45-12	CI GJS 600	Steel ETG-100
Ø 0.156 – 0.375	450 bar / 6500 psi				
Ø 0.406 – 0.875	450 bar / 6500 psi				
Hole	Tolerance	0 / + 0.004 in			
	Roughness	Anchorage in Base Material			R _z 10 – 30 µm

Max. Allowable Working Pressure = Nominal Pressure

Please note these recommendations are generally conservative and higher working pressures are possible in some applications. Please contact your local applications engineer with any questions.

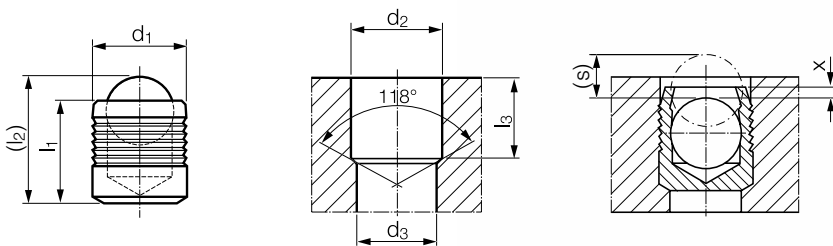

Material:

Sleeve: Stainless Steel (316) ASTM A580, Passivate, QQ-P-35C

Ball: Stainless Steel, AISI 316, Wax Film Lubrication (Diameter Dependant)

KOENIG EXPANDER® SEALING PLUGS Series CV 851 Inch

3D DATA: www.sfckoenig.com

Part Number	Order Number	d ₁	l ₁	(l ₂) ~ Ref.	d ₂ +0.004 0	d ₃ max.	l ₃ min.	x ±0.004	(s) ~ Ref.	Packaging Unit	Weight in gram/pcs.
CV 851-156	300169534	0.156	0.158	0.21	0.1562	0.130	0.149	0.008	0.053	100 / 1000	0.34
CV 851-187	300169536	0.187	0.217	0.27	0.1875	0.160	0.208	0.010	0.066	100 / 1000	0.69
CV 851-218	300169538	0.218	0.217	0.28	0.2187	0.190	0.208	0.010	0.078	100 / 1000	0.92
CV 851-250	300169540	0.250	0.256	0.34	0.2500	0.220	0.247	0.010	0.094	100 / 1000	1.40
CV 851-281	300169542	0.281	0.296	0.40	0.2812	0.250	0.287	0.010	0.110	100 / 1000	2.87
CV 851-312	300169544	0.312	0.335	0.46	0.3125	0.281	0.326	0.010	0.129	100 / 1000	3.83
CV 851-343	300169546	0.343	0.394	0.52	0.3437	0.312	0.385	0.010	0.140	100 / 500	4.03
CV 851-375	300169548	0.375	0.394	0.54	0.3750	0.343	0.385	0.010	0.153	100 / 500	4.77
CV 851-406	300169549	0.406	0.434	0.59	0.4062	0.375	0.425	0.010	0.162	100 / 500	6.20
CV 851-437	300169551	0.437	0.512	0.68	0.4375	0.406	0.503	0.010	0.166	50 / 250	8.49
CV 851-468	300169552	0.468	0.512	0.71	0.4687	0.437	0.503	0.010	0.199	50 / 250	9.51
CV 851-562	300169553	0.562	0.591	0.82	0.5625	0.510	0.570	0.010	0.233	50 / 250	15.40
CV 851-625	300169554	0.625	0.669	0.91	0.6250	0.562	0.649	0.010	0.252	25 / 100	22.90
CV 851-687	300169555	0.687	0.748	1.03	0.6875	0.625	0.727	0.010	0.289	25 / 100	30.60
CV 851-750	300169556	0.750	0.866	1.18	0.7500	0.688	0.845	0.010	0.317	25 / 100	41.57
CV 851-875	300169557	0.875	0.984	1.35	0.8750	0.813	0.963	0.010	0.354	25 / 50	65.63

Dimensions in inches

Not all items in stock – production MOQ & lead times may apply

Performance data can be provided for specific applications upon request

PRESSURE PERFORMANCE

Series CV 851 Inch	Base Material of the Installation				
	Al A356	Al 2024-T4	CI 60-45-12	CI GJS 600	Steel ETG-100
Ø 0.156 – 0.375	450 bar / 6500 psi				
Ø 0.406 – 0.875	450 bar / 6500 psi				
Hole	Tolerance	0 / + 0.004 in			
	Roughness	Anchorage in Base Material		R _z 10 – 30 µm	

Max. Allowable Working Pressure = Nominal Pressure

Please note these recommendations are generally conservative and higher working pressures are possible in some applications. Please contact your local applications engineer with any questions.

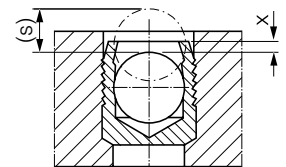
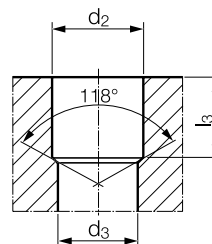
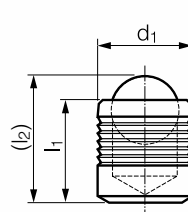

Material:

Sleeve: Case Hardening Steel ASTM A108, Zinc Chromate ASTM B633: Type III, Trivalent
 Ball: Bearing Steel, Heat Treated, Black Oxide + Wax Film Lubrication (Diameter Dependant)

KOENIG EXPANDER® SEALING PLUGS Series CV 143 Inch Short

3D DATA: www.sfckoenig.com

Part Number	Order Number	d ₁	l ₁	(l ₂) ~ Ref.	d ₂ +0.004 0	d ₃ max.	l ₃ min.	x ±0.004	(s) ~ Ref.	Packaging Unit	Weight in gram/pcs.
CV 143-125S	300169202	0.125	0.125	0.16	0.1250	0.100	0.113	0.007	0.042	100 / 1000	0.10
CV 143-156S	300169205	0.156	0.125	0.17	0.1562	0.130	0.113	0.000	0.040	100 / 1000	0.15
CV 143-187S	300169210	0.187	0.187	0.24	0.1875	0.160	0.170	0.010	0.066	100 / 1000	0.33
CV 143-218S	300169213	0.218	0.187	0.25	0.2187	0.190	0.170	0.000	0.063	100 / 1000	0.46
CV 143-250S	300169216	0.250	0.225	0.30	0.2500	0.220	0.196	0.000	0.083	100 / 1000	0.76
CV 143-281S	300169218	0.281	0.255	0.35	0.2812	0.250	0.233	0.000	0.091	100 / 1000	1.08
CV 143-312S	300169220	0.312	0.280	0.39	0.3125	0.281	0.255	0.000	0.107	100 / 1000	1.52
CV 143-343S	300169222	0.343	0.307	0.43	0.3437	0.312	0.275	0.000	0.118	100 / 500	2.04
CV 143-406S	300169225	0.406	0.365	0.52	0.4062	0.375	0.308	-0.010	0.143	100 / 500	3.60

Dimensions in inches

Not all items in stock – production MOQ & lead times may apply

Performance data can be provided for specific applications upon request

PRESSURE PERFORMANCE

Series CV 143 Inch Short		Base Material of the Installation				
		Al A356	Al 2024-T4	Cl 60-45-12	Cl GJS 600	Steel ETG-100
Ø 0.125 – 0.406			120 bar / 1750 psi			
Hole	Tolerance	0 / + 0.004 in				
	Roughness	Anchorage	R _z 10 – 30 µm			

Max. Allowable Working Pressure = Nominal Pressure

Please note these recommendations are generally conservative and higher working pressures are possible in some applications. Please contact your local applications engineer with any questions.

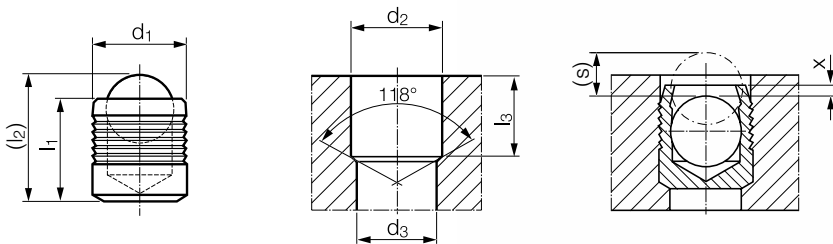

Material:

Sleeve: Aluminum 2024-T4, QQ-A 225/6, Anodized Green, MIL-A-8625:

Type II Class 2

Ball: Stainless Steel, AISI 302/304, Wax Film Lubrication (Diameter Dependant)



KOENIG EXPANDER® SEALING PLUGS Series CV 163 Inch Short

3D DATA: www.sfckoenig.com

Part Number	Order Number	d ₁	l ₁	(l ₂) ~ Ref.	d ₂ +0.004 0	d ₃ max.	l ₃ min.	x ±0.004	(s) ~ Ref.	Packaging Unit	Weight in gram/pcs.
CV 163-125S	300169242	0.125	0.125	0.16	0.1250	0.100	0.113	0.007	0.042	100 / 1000	0.10
CV 163-156S	300169245	0.156	0.125	0.17	0.1562	0.130	0.113	0.000	0.040	100 / 1000	0.15
CV 163-187S	300169249	0.187	0.187	0.24	0.1875	0.160	0.170	0.010	0.066	100 / 1000	0.33
CV 163-218S	300169252	0.218	0.187	0.25	0.2187	0.190	0.170	0.000	0.063	100 / 1000	0.46
CV 163-250S	300169255	0.250	0.225	0.30	0.2500	0.220	0.196	0.000	0.083	100 / 1000	0.76
CV 163-281S	300169257	0.281	0.255	0.35	0.2812	0.250	0.233	0.000	0.091	100 / 1000	1.08
CV 163-312S	300169259	0.312	0.280	0.39	0.3125	0.281	0.255	0.000	0.107	100 / 1000	1.52
CV 163-343S	300169261	0.343	0.307	0.43	0.3437	0.312	0.275	0.000	0.118	100 / 500	2.01
CV 163-406S	300169264	0.406	0.365	0.52	0.4062	0.375	0.308	-0.010	0.143	100 / 500	3.59

Dimensions in inches

Not all items in stock – production MOQ & lead times may apply

Performance data can be provided for specific applications upon request

PRESSURE PERFORMANCE

Series CV 163 Inch Short		Base Material of the Installation				
		Al A356	Al 2024-T4	CI 60-45-12	CI GJS 600	Steel ETG-100
Ø 0.125 – 0.406			120 bar / 1750 psi			
Hole	Tolerance	0 / + 0.004 in				
	Roughness	Anchorage	R _Z 10 – 30 µm			

Max. Allowable Working Pressure = Nominal Pressure

Please note these recommendations are generally conservative and higher working pressures are possible in some applications. Please contact your local applications engineer with any questions.

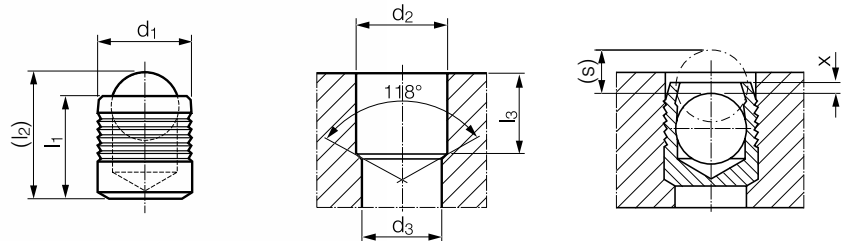

Material:

Sleeve: Aluminum 2024-T4, QQ-A 225/6, Allodined Chromate Conversion, MIL-C-5541

Ball: Stainless Steel, AISI 302/304, Wax Film Lubrication (Diameter Dependant)



KOENIG EXPANDER® SEALING PLUGS Series CV 173 Inch Short

3D DATA: www.sfckoenig.com

Part Number	Order Number	d ₁	l ₁	(I ₂) ~ Ref.	d ₂ +0.004 0	d ₃ max.	l ₃ min.	x ±0.004	(s) ~ Ref.	Packaging Unit	Weight in gram/pcs.
CV 173-125S	300169284	0.125	0.125	0.16	0.1250	0.100	0.113	0.007	0.042	100 / 1000	0.10
CV 173-156S	300169287	0.156	0.125	0.17	0.1562	0.130	0.113	0.000	0.040	100 / 1000	0.15
CV 173-187S	300169290	0.187	0.187	0.24	0.1875	0.160	0.170	0.010	0.066	100 / 1000	0.33
CV 173-218S	300169292	0.218	0.187	0.25	0.2187	0.190	0.170	0.000	0.063	100 / 1000	0.46
CV 173-250S	300169294	0.250	0.225	0.30	0.2500	0.220	0.196	0.000	0.083	100 / 1000	0.76
CV 173-281S	300169296	0.281	0.255	0.35	0.2812	0.250	0.233	0.000	0.091	100 / 1000	1.08
CV 173-312S	300169298	0.312	0.280	0.39	0.3125	0.281	0.255	0.000	0.107	100 / 1000	1.52
CV 173-343S	300169300	0.343	0.307	0.43	0.3437	0.312	0.275	0.000	0.118	100 / 500	2.01
CV 173-406S	300169303	0.406	0.365	0.52	0.4062	0.375	0.308	-0.010	0.143	100 / 500	3.59

Dimensions in inches

Not all items in stock – production MOQ & lead times may apply

Performance data can be provided for specific applications upon request

PRESSURE PERFORMANCE

Series CV 173 Inch Short		Base Material of the Installation				
		Al A356	Al 2024-T4	Cl 60-45-12	Cl GJS 600	Steel ETG-100
Ø 0.125 – 0.406			120 bar / 1750 psi			
Hole	Tolerance	0 / + 0.004 in				
	Roughness	Anchorage	R _z 10 – 30 µm			

Max. Allowable Working Pressure = Nominal Pressure

Please note these recommendations are generally conservative and higher working pressures are possible in some applications. Please contact your local applications engineer with any questions.

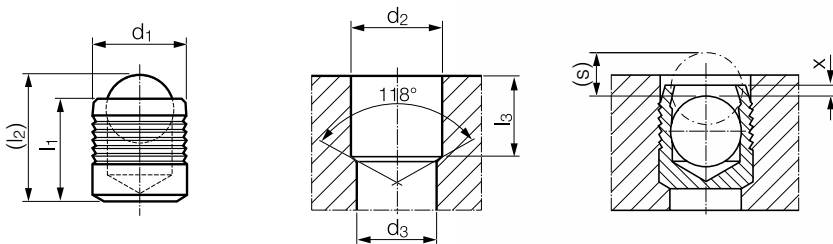

Material:

Sleeve: Aluminum 2024-T4, QQ-A 225/6

Ball: Stainless Steel, AISI 302/304, Wax Film Lubrication (Diameter Dependant)



KOENIG EXPANDER® SEALING PLUGS Series CV 531 Inch Short

3D DATA: www.sfckoenig.com

Part Number	Order Number	d ₁	l ₁	(l ₂) ~ Ref.	d ₂ +0.004 0	d ₃ max.	l ₃ min.	x ±0.004	(s) ~ Ref.	Packaging Unit	Weight in gram/pcs.
CV 531-125S	-	0.125	0.125	0.16	0.1250	0.100	0.113	0.007	0.042	100 / 1000	0.18
CV 531-156S	300169353	0.156	0.125	0.17	0.1562	0.130	0.113	0.000	0.040	100 / 1000	0.29
CV 531-187S	300169355	0.187	0.187	0.24	0.1875	0.160	0.170	0.010	0.066	100 / 1000	0.58
CV 531-218S	300169357	0.218	0.187	0.25	0.2187	0.190	0.170	0.000	0.063	100 / 1000	0.81
CV 531-250S	300169359	0.250	0.225	0.30	0.2500	0.220	0.196	0.000	0.083	100 / 1000	1.19
CV 531-281S	300169361	0.281	0.255	0.35	0.2812	0.250	0.233	0.000	0.091	100 / 1000	1.76
CV 531-312S	300169363	0.312	0.280	0.39	0.3125	0.281	0.255	0.000	0.107	100 / 1000	2.36
CV 531-343S	300169364	0.343	0.307	0.43	0.3437	0.312	0.275	0.000	0.118	100 / 500	3.08
CV 531-406S	300176288	0.406	0.365	0.52	0.4062	0.375	0.308	-0.010	0.143	100 / 500	5.13

Dimensions in inches

Not all items in stock – production MOQ & lead times may apply

Performance data can be provided for specific applications upon request

PRESSURE PERFORMANCE

Series CV 531 Inch Short		Base Material of the Installation			
		Al A356	Al 2024-T4	CI 60-45-12	CI GJS 600
Ø 0.125 – 0.406		300 bar / 4500 psi			
Hole	Tolerance	0 / + 0.004 in			
	Roughness	Anchorage in Base Material			R _Z 10 – 30 µm

Max. Allowable Working Pressure = Nominal Pressure

Please note these recommendations are generally conservative and higher working pressures are possible in some applications. Please contact your local applications engineer with any questions.

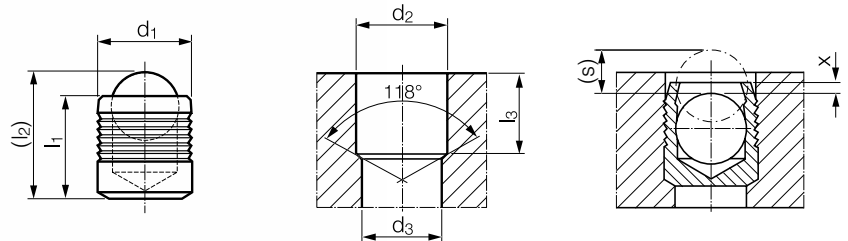

Material:

Sleeve: Stainless Steel [303] ASTM A582

Ball: Bearing Steel, Heat Treated, Black Oxide + Wax Film

Lubrication (Diameter Dependant)



KOENIG EXPANDER® SEALING PLUGS Series CV 533 Inch Short

3D DATA: www.sfckoenig.com

Part Number	Order Number	d ₁	l ₁	(l ₂) ~ Ref.	d ₂ +0.004 0	d ₃ max.	l ₃ min.	x ±0.004	(s) ~ Ref.	Packaging Unit	Weight in gram/pcs.
CV 533-125S	300169381	0.125	0.125	0.16	0.1250	0.100	0.113	0.007	0.042	100 / 1000	0.18
CV 533-156S	300169384	0.156	0.125	0.17	0.1562	0.130	0.113	0.000	0.040	100 / 1000	0.29
CV 533-187S	300169370	0.187	0.187	0.24	0.1875	0.160	0.170	0.010	0.066	100 / 1000	0.60
CV 533-218S	300169388	0.218	0.187	0.25	0.2187	0.190	0.170	0.000	0.063	100 / 1000	0.81
CV 533-250S	300169390	0.250	0.225	0.30	0.2500	0.220	0.196	0.000	0.083	100 / 1000	1.20
CV 533-281S	300169392	0.281	0.255	0.35	0.2812	0.250	0.233	0.000	0.091	100 / 1000	1.77
CV 533-312S	300169394	0.312	0.280	0.39	0.3125	0.281	0.255	0.000	0.107	100 / 1000	2.38
CV 533-343S	300169396	0.343	0.307	0.43	0.3437	0.312	0.275	0.000	0.118	100 / 500	3.11
CV 533-406S	300169399	0.406	0.365	0.52	0.4062	0.375	0.308	-0.010	0.143	100 / 500	5.18

Dimensions in inches

Not all items in stock – production MOQ & lead times may apply

Performance data can be provided for specific applications upon request

PRESSURE PERFORMANCE

Series CV 533 Inch Short		Base Material of the Installation			
		Al A356	Al 2024-T4	Cl 60-45-12	Cl GJS 600
Ø 0.125 – 0.406		300 bar / 4500 psi			
Hole	Tolerance	0 / + 0.004 in			
	Roughness	Anchorage in Base Material			R _z 10 – 30 µm

Max. Allowable Working Pressure = Nominal Pressure

Please note these recommendations are generally conservative and higher working pressures are possible in some applications. Please contact your local applications engineer with any questions.

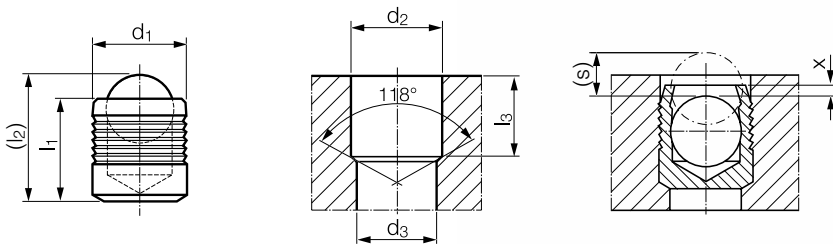

Material:

Sleeve: Stainless Steel (303) ASTM A582

Ball: Stainless Steel, AISI 302/304, Wax Film Lubrication (Diameter Dependant)



KOENIG EXPANDER® SEALING PLUGS Series CV 588 Inch Short

3D DATA: www.sfckoenig.com

Part Number	Order Number	d ₁	l ₁	(l ₂) ~ Ref.	d ₂ +0.004 0	d ₃ max.	l ₃ min.	x ±0.004	(s) ~ Ref.	Packaging Unit	Weight in gram/pcs.
CV 588-093S	300170124	0.093	0.098	0.12	0.0937	0.070	0.081	0.005	0.029	100 / 1000	0.09
CV 588-125S	300169502	0.125	0.125	0.16	0.1250	0.100	0.113	0.007	0.042	100 / 1000	0.18
CV 588-156S	300169505	0.156	0.125	0.17	0.1562	0.130	0.113	0.000	0.040	100 / 1000	0.29
CV 588-187S	300169510	0.187	0.187	0.24	0.1875	0.160	0.170	0.010	0.066	100 / 1000	0.60
CV 588-218S	300169513	0.218	0.187	0.25	0.2187	0.190	0.170	0.000	0.063	100 / 1000	0.81
CV 588-250S	300169690	0.250	0.225	0.30	0.2500	0.220	0.196	0.000	0.083	100 / 1000	1.20
CV 588-281S	300169518	0.281	0.255	0.35	0.2812	0.250	0.233	0.000	0.091	100 / 1000	1.77
CV 588-312S	300169520	0.312	0.280	0.39	0.3125	0.281	0.255	0.000	0.107	100 / 1000	2.38
CV 588-343S	300169522	0.343	0.307	0.43	0.3437	0.312	0.275	0.000	0.118	100 / 500	3.11
CV 588-406S	300169525	0.406	0.365	0.52	0.4062	0.375	0.308	-0.010	0.143	100 / 500	5.18

Dimensions in inches

Not all items in stock – production MOQ & lead times may apply

Performance data can be provided for specific applications upon request

PRESSURE PERFORMANCE

Series CV 588 Inch Short		Base Material of the Installation				
		Al A356	Al 2024-T4	CI 60-45-12	CI GJS 600	Steel ETG-100
Ø 0.093 – 0.406		250 bar / 3600 psi				
Hole	Tolerance	0 / + 0.004 in				
	Roughness	Anchorage in Base Material				R _z 10 – 30 µm

Max. Allowable Working Pressure = Nominal Pressure

Please note these recommendations are generally conservative and higher working pressures are possible in some applications. Please contact your local applications engineer with any questions.

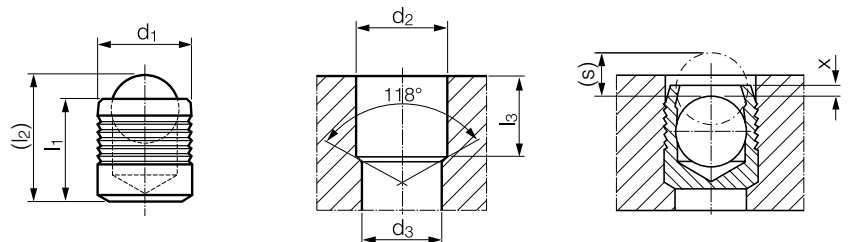

Material:

Sleeve: Stainless Steel AISI 316, ASTM A580, Passivate, QQ-P-35C

Ball: Stainless Steel, AISI 316, Wax Film Lubrication (Diameter Dependant)



KOENIG EXPANDER® SEALING PLUGS Series CV 851 Inch Short

3D DATA: www.sfckoenig.com

Part Number	Order Number	d ₁	l ₁	(l ₂) ~ Ref.	d ₂ +0.004 0	d ₃ max.	l ₃ min.	x ±0.004	(s) ~ Ref.	Packaging Unit	Weight in gram/pcs.
CV 851-125S	-	0.125	0.125	0.16	0.1250	0.100	0.113	0.007	0.042	100 / 1000	0.17
CV 851-156S	300169535	0.156	0.125	0.17	0.1562	0.130	0.113	0.000	0.040	100 / 1000	0.28
CV 851-187S	300169537	0.187	0.187	0.24	0.1875	0.160	0.170	0.010	0.066	100 / 1000	0.58
CV 851-218S	300169539	0.218	0.187	0.25	0.2187	0.190	0.170	0.000	0.063	100 / 1000	0.80
CV 851-250S	300169541	0.250	0.225	0.30	0.2500	0.220	0.196	0.000	0.083	100 / 1000	1.18
CV 851-281S	300169543	0.281	0.255	0.35	0.2812	0.250	0.233	0.000	0.091	100 / 1000	1.74
CV 851-312S	300169545	0.312	0.280	0.39	0.3125	0.281	0.255	0.000	0.107	100 / 1000	2.34
CV 851-343S	300169547	0.343	0.307	0.43	0.3437	0.312	0.275	0.000	0.118	100 / 500	3.06
CV 851-406S	300169550	0.406	0.365	0.52	0.4062	0.375	0.308	-0.010	0.143	100 / 500	5.09

Dimensions in inches

Not all items in stock – production MOQ & lead times may apply

Performance data can be provided for specific applications upon request

PRESSURE PERFORMANCE

Series CV 851 Inch Short		Base Material of the Installation			
		Al A356	Al 2024-T4	Cl 60-45-12	Cl GJS 600
Ø 0.125 – 0.406		250 bar / 3600 psi			
Hole	Tolerance	0 / + 0.004 in			
	Roughness	Anchorage in Base Material			R _z 10 – 30 µm

Max. Allowable Working Pressure = Nominal Pressure

Please note these recommendations are generally conservative and higher working pressures are possible in some applications. Please contact your local applications engineer with any questions.

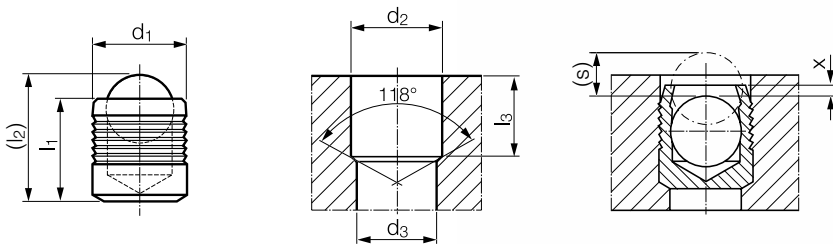

Material:

Sleeve: Case Hardening Steel ASTM A108, Zinc Chromate ASTM B633:

Type III, Trivalent

Ball: Bearing Steel, Heat Treated, Black Oxide + Wax Film

Lubrication (Diameter Dependant)



KOENIG EXPANDER® SETTING TOOLS Series CV

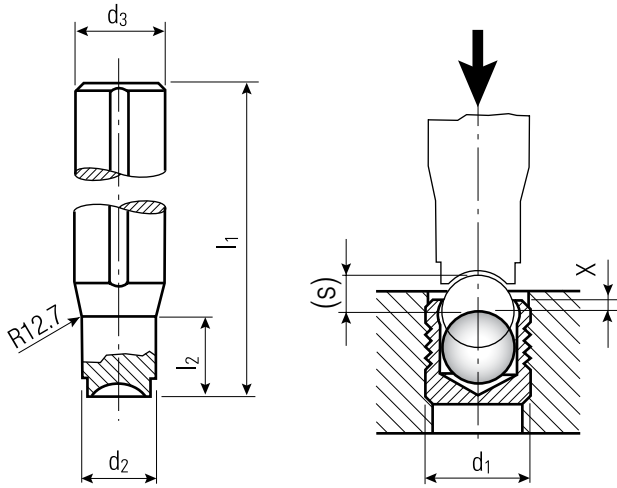

3D DATA: www.sfckoenig.com

Part Number	Order Number	d ₁ Expander	d ₃ ±0.12	l ₁	d ₂	l ₂	x ±0.10	(s) ~ Ref.	Weight in gram/pcs.
HT-MBM-030	300171079	MB/CV XXX-030	9.53	127	2.8	7.6	0.2	1.0	62
HT-MBM-040	300171080	MB/CV XXX-040	9.53	127	3.8	7.6	0.2	1.4	63
HT-MBM-050	300171081	MB/CV XXX-050	9.53	127	4.8	12.7	0.2	1.9	62
HT-MBM-060	300171082	MB/CV XXX-060	9.53	127	5.8	15.2	0.2	2.3	63
HT-MBM-070	300171083	MB/CV XXX-070	9.53	127	6.8	20.3	0.2	2.8	63
HT-MBM-080	300171084	MB/CV XXX-080	9.53	127	7.8	33.0	0.2	3.4	63
HT-MBM-090	300171085	MB/CV XXX-090	12.70	127	8.8	38.1	0.2	3.7	102
HT-MBM-100	300171086	MB/CV XXX-100	12.70	127	9.8	38.1	0.2	4.2	107
HT-MBM-120	300171087	MB/CV XXX-120	12.70	127	11.7	38.1	0.2	5.1	118
HT-MBM-140	300171089	MB/CV XXX-140	15.88	127	13.7	45.7	0.2	5.9	174
HT-MBM-160	300171052	MB/CV XXX-160	15.88	127	15.7	45.7	0.2	6.4	192
HT-MBM-180	300170549	MB/CV XXX-180	19.05	127	17.7	45.7	0.2	7.2	264
HT-MBM-200	300171054	MB/CV XXX-200	22.23	127	19.7	45.7	0.2	8.4	347
HT-MBM-220	300176297	MB/CV XXX-220	25.40	127	21.7	45.7	0.2	9.5	442

Dimensions in millimeters

Not all items in stock – production MOQ & lead times may apply

Material:

Tool Steel, Heat Treated, Hardness Approx. HRC 50

RECOMMENDED SETTING EQUIPMENT FOR SERIES CV

EXPRESS 3000	Hydropneumatic Table Press	See page 74 for more information
EXPRESS 5000	Hydropneumatic Table Press	See page 74 for more information

KOENIG EXPANDER® SETTING TOOLS Series CV Air Hammer

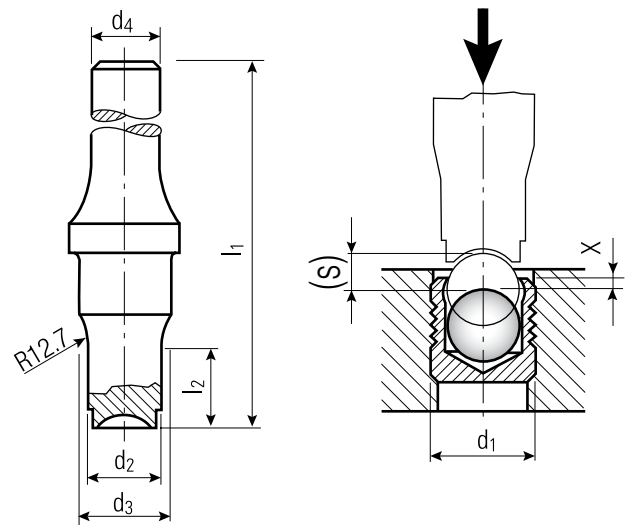

Part Number	Order Number	d ₁ Expander	d ₃ ±0.12	d ₄ (AH only)	l ₁	d ₂	l ₂	x ±0.10	(s) ~ Ref.	Weight in gram/pcs.
AH-MBM-030	300168334	MB/CV XXX-030	12.7	10.2	101.6	2.8	7.6	0.2	1.0	83
AH-MBM-040	300168335	MB/CV XXX-040	12.7	10.2	101.6	3.8	7.6	0.2	1.4	84
AH-MBM-050	300168336	MB/CV XXX-050	12.7	10.2	101.6	4.8	12.7	0.2	1.9	81
AH-MBM-060	300168337	MB/CV XXX-060	12.7	10.2	101.6	5.8	15.2	0.2	2.3	81
AH-MBM-070	300168338	MB/CV XXX-070	12.7	10.2	101.6	6.8	20.3	0.2	2.8	79
AH-MBM-080	300168339	MB/CV XXX-080	12.7	10.2	101.6	7.8	33.0	0.2	3.4	74
AH-MBM-090	300168340	MB/CV XXX-090	12.7	10.2	101.6	8.8	33.0	0.2	3.7	78
AH-MBM-100	300170427	MB/CV XXX-100	12.7	10.2	101.6	9.8	38.1	0.2	4.2	80
AH-MBM-120	300168341	MB/CV XXX-120	12.7	10.2	101.6	11.7	38.1	0.2	5.1	91
AH-MBM-140	300168342	MB/CV XXX-140	12.7	10.2	101.6	13.7	-	0.2	5.9	98
AH-MBM-160	300168343	MB/CV XXX-160	12.7	10.2	101.6	15.7	-	0.2	6.4	101
AH-MBM-180	300168344	MB/CV XXX-180	12.7	10.2	101.6	17.7	-	0.2	7.2	105
AH-MBM-200	300176285	MB/CV XXX-200	12.7	10.2	101.6	19.7	-	0.2	8.4	110
AH-MBM-220	300176286	MB/CV XXX-220	12.7	10.2	101.6	21.7	-	0.2	9.5	116

Dimensions in millimeters

Not all items in stock – production MOQ & lead times may apply

Material:

Tool Steel, Heat Treated, Hardness Approx. HRC 50

RECOMMENDED SETTING EQUIPMENT FOR SERIES CV

EXPRESS 3000	Hydropneumatic Table Press	See page 74 for more information
EXPRESS 5000	Hydropneumatic Table Press	See page 74 for more information

KOENIG EXPANDER® SETTING TOOLS Series CV

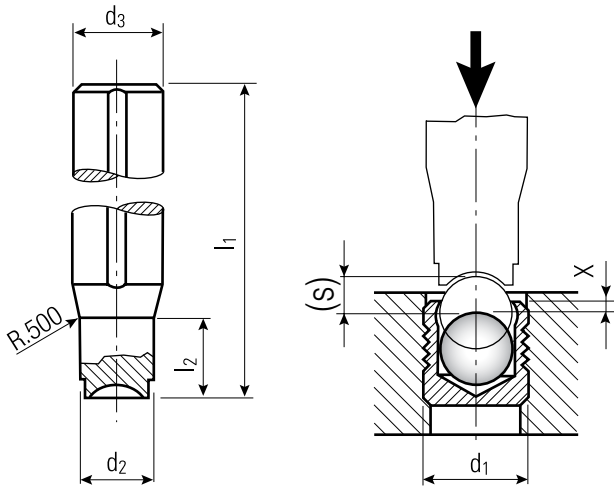

3D DATA: www.sfckoenig.com

Part Number	Order Number	d ₁ Expander	d ₃ ±0.005	l ₁	d ₂	l ₂	x ±0.004	(s) ~ Ref.	Weight in gram/pcs.
HT-CVI-156	300171068	CV XXX-156	0.375	5.0	0.142	0.3	0.008	0.053	63
HT-CVI-187	300171069	CV XXX-187	0.375	5.0	0.173	0.4	0.010	0.066	63
HT-CVI-218	300171070	CV XXX-218	0.375	5.0	0.204	0.5	0.010	0.063	63
HT-CVI-250	300171072	CV XXX-250	0.375	5.0	0.236	0.6	0.010	0.083	63
HT-CVI-281	300171073	CV XXX-281	0.375	5.0	0.267	0.8	0.010	0.110	63
HT-CVI-312	300171074	CV XXX-312	0.375	5.0	0.298	1.3	0.010	0.107	62
HT-CVI-343	300171075	CV XXX-343	0.500	5.0	0.329	1.5	0.010	0.140	100
HT-CVI-375	300170645	CV XXX-375	0.500	5.0	0.361	1.5	0.010	0.153	104
HT-CVI-406	300171076	CV XXX-406	0.500	5.0	0.392	1.5	0.010	0.162	108
HT-CVI-437	300171077	CV XXX-437	0.500	5.0	0.423	1.5	0.010	0.166	112
HT-CVI-562	300169970	CV XXX-562	0.625	5.0	0.548	1.8	0.010	0.233	176
HT-CVI-625	300167850	CV XXX-625	0.625	5.0	0.611	1.8	0.010	0.252	190
HT-CVI-687	300171078	CV XXX-687	0.750	5.0	0.673	1.8	0.010	0.289	258
HT-CVI-750	300169999	CV XXX-750	0.875	5.0	0.736	1.8	0.010	0.317	336
HT-CVI-875	300169763	CV XXX-875	1.000	5.0	0.861	1.8	0.010	0.354	445

Dimensions in inches

Not all items in stock – production MOQ & lead times may apply

Material:

Tool Steel, Heat Treated, Hardness Approx. HRC 50

RECOMMENDED SETTING EQUIPMENT FOR SERIES CV

EXPRESS 3000	Hydropneumatic Table Press	See page 74 for more information
EXPRESS 5000	Hydropneumatic Table Press	See page 74 for more information

KOENIG EXPANDER® SETTING TOOLS Series CV Air Hammer

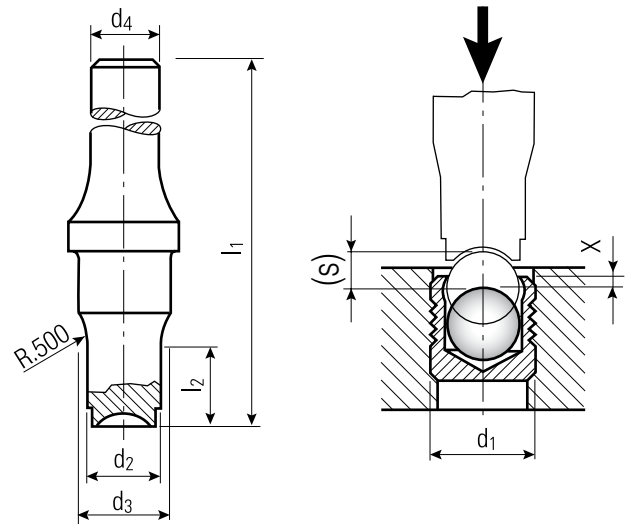

Part Number	Order Number	d ₁ Expander	d ₃ ±0.005	d ₄	l ₁	d ₂	l ₂	x ±0.004	(s) ~ Ref.	Weight in gram/pcs.
AH-CVI-156	300176276	CV XXX-156	0.5	0.401	4.0	0.142	0.3	0.008	0.053	84
AH-CVI-187	300168327	CV XXX-187	0.5	0.401	4.0	0.173	0.4	0.010	0.066	83
AH-CVI-218	300168328	CV XXX-218	0.5	0.401	4.0	0.204	0.5	0.010	0.063	82
AH-CVI-250	300168329	CV XXX-250	0.5	0.401	4.0	0.236	0.6	0.010	0.083	81
AH-CVI-281	300168330	CV XXX-281	0.5	0.401	4.0	0.267	0.8	0.010	0.110	79
AH-CVI-312	300170426	CV XXX-312	0.5	0.401	4.0	0.298	1.3	0.010	0.107	73
AH-CVI-343	300176278	CV XXX-343	0.5	0.401	4.0	0.329	1.3	0.010	0.140	73
AH-CVI-375	300168331	CV XXX-375	0.5	0.401	4.0	0.361	1.5	0.010	0.153	77
AH-CVI-406	300176279	CV XXX-406	0.5	0.401	4.0	0.392	1.5	0.010	0.162	81
AH-CVI-437	300176280	CV XXX-437	0.5	0.401	4.0	0.423	1.5	0.010	0.166	86
AH-CVI-562	300176281	CV XXX-562	0.5	0.401	4.0	0.548	-	0.010	0.233	99
AH-CVI-625	300168332	CV XXX-625	0.5	0.401	4.0	0.611	-	0.010	0.252	101
AH-CVI-687	300168333	CV XXX-687	0.5	0.401	4.0	0.673	-	0.010	0.289	104
AH-CVI-750	300176282	CV XXX-750	0.5	0.401	4.0	0.736	-	0.010	0.317	108
AH-CVI-875	300176283	CV XXX-875	0.5	0.401	4.0	0.861	-	0.010	0.354	117

Dimensions in inches

Not all items in stock – production MOQ & lead times may apply

Material:

Tool Steel, Heat Treated, Hardness Approx. HRC 50

RECOMMENDED SETTING EQUIPMENT FOR SERIES CV

EXPRESS 3000	Hydropneumatic Table Press	See page 74 for more information
EXPRESS 5000	Hydropneumatic Table Press	See page 74 for more information

KOENIG EXPANDER® SETTING TOOLS Series CV Short

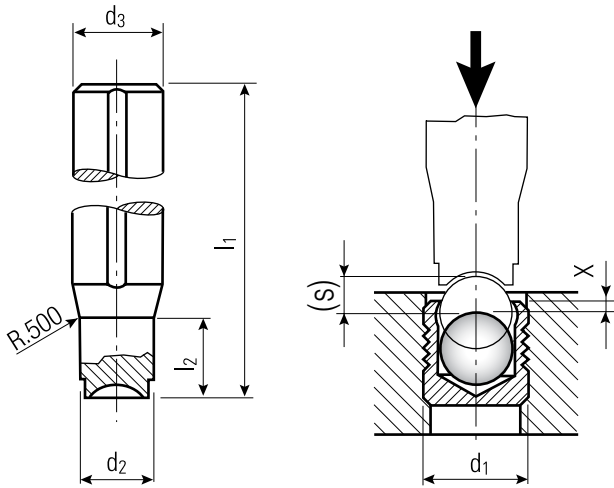

Part Number	Order Number	d ₁ Expander	d ₃ ±0.005	l ₁	d ₂	l ₂	x ±0.004	(s) ~ Ref.	Weight in gram/pcs.
HT-CVI-125	300171069	CV XXX-125S	0.375	5.0	0.111	0.3	0.007	0.042	62
HT-CVI-156-S	300171071	CV XXX-156S	0.375	5.0	0.142	0.3	0.000	0.040	63
HT-CVI-187	300171072	CV XXX-187S	0.375	5.0	0.173	0.4	0.010	0.066	63
HT-CVI-218	300171073	CV XXX-218S	0.375	5.0	0.204	0.5	0.010	0.063	63
HT-CVI-250	300171074	CV XXX-250S	0.375	5.0	0.236	0.6	0.010	0.083	63
HT-CVI-281-S	300169906	CV XXX-281S	0.375	5.0	0.267	0.8	0.000	0.091	63
HT-CVI-312	300170645	CV XXX-312S	0.375	5.0	0.298	1.3	0.010	0.107	62
HT-CVI-343	300171076	CV XXX-343S	0.500	5.0	0.329	1.5	0.010	0.118	100
HT-CVI-406	300169970	CV XXX-406S	0.500	5.0	0.392	1.5	0.010	0.143	108

Dimensions in inches

Not all items in stock – production MOQ & lead times may apply

Material:

Tool Steel, Heat Treated, Hardness Approx. HRC 50

RECOMMENDED SETTING EQUIPMENT FOR SERIES CV

EXPRESS 3000	Hydropneumatic Table Press	See page 74 for more information
EXPRESS 5000	Hydropneumatic Table Press	See page 74 for more information

KOENIG EXPANDER® SETTING TOOLS Series CV Short Air Hammer

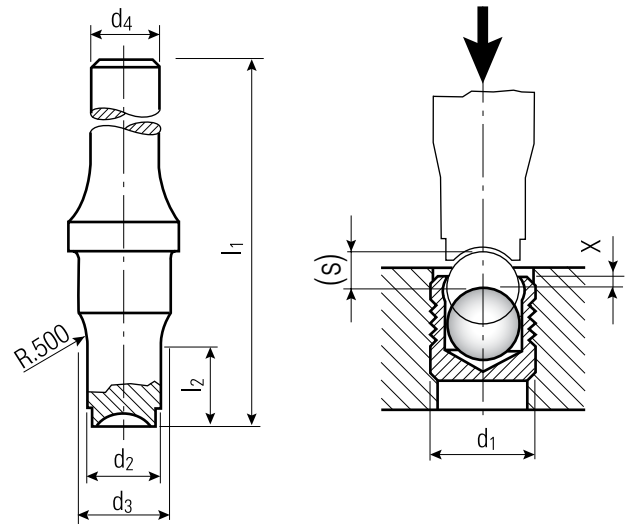

Part Number	Order Number	d ₁ Expander	d ₃ ±0.005	d ₄	l ₁	d ₂	l ₂	x ±0.004	(s) ~ Ref.	Weight in gram/pcs.
AH-CVI-125	300176276	CV XXX-125S	0.5	0.401	4.0	0.111	0.3	0.007	0.042	83
AH-CVI-156-S	300176277	CV XXX-156S	0.5	0.401	4.0	0.142	0.3	0.000	0.040	84
AH-CVI-187	300168328	CV XXX-187S	0.5	0.401	4.0	0.173	0.4	0.010	0.066	83
AH-CVI-218	300168329	CV XXX-218S	0.5	0.401	4.0	0.204	0.5	0.010	0.063	82
AH-CVI-250	300168330	CV XXX-250S	0.5	0.401	4.0	0.236	0.6	0.010	0.083	81
AH-CVI-281-S	300169913	CV XXX-281S	0.5	0.401	4.0	0.267	0.8	0.000	0.091	79
AH-CVI-312	300176278	CV XXX-312S	0.5	0.401	4.0	0.298	1.3	0.010	0.107	73
AH-CVI-343	300168331	CV XXX-343S	0.5	0.401	4.0	0.329	1.3	0.010	0.118	76
AH-CVI-406	300176280	CV XXX-406S	0.5	0.401	4.0	0.329	1.5	0.010	0.143	81

Dimensions in inches

Not all items in stock – production MOQ & lead times may apply.

Material:

Tool Steel, Heat Treated, Hardness Approx. HRC 50

RECOMMENDED SETTING EQUIPMENT FOR SERIES CV

EXPRESS 3000	Hydropneumatic Table Press	See page 74 for more information
EXPRESS 5000	Hydropneumatic Table Press	See page 74 for more information



Full Line of Sealing & Flow Control Technologies

KOENIG EXPANDER®

Series SK

Sealing Plugs for Operating Pressures up to 500 bar / 7200 psi

- Operating pressures up to 500 bar / 7200 psi
- Short installation length
- Liberal manufacturing tolerance 0 / + 0.12 mm
- Direct installation into hydraulic bores
- Purely mechanical sealing through anchorage system
- Swift installation using convenient processing tools

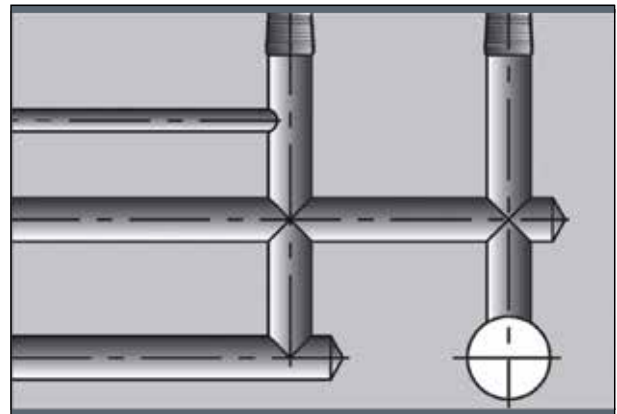
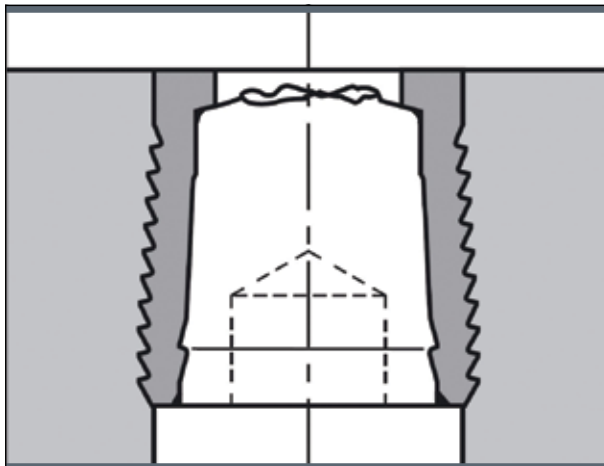

Please inquire with our sales or applications engineers about requirements for special materials or configurations not shown in the catalog.

RECOMMENDED SETTING EQUIPMENT FOR SERIES SK

KW-008	Hand Lever Tool with Equipment $\varnothing 4 - 6$ mm
EXTOOL-030	Hydraulic/Pneumatic Tool
EXTOOL-040-1	Hydraulic/Pneumatic Tool
EXTOOL-040-2	Hydraulic/Pneumatic Tool

See page 78 for more information
See page 75 for more information
See page 76 for more information
See page 77 for more information



KOENIG EXPANDER® SEALING PLUGS Series SK 550

One Piece Construction, Ideal for Automated High Production Requirements

3D DATA: www.sfckoenig.com

Part Number	Order Number	d ₁	l ₁	d ₂	l ₂	l ₃ max.	l ₄ max.	d ₃ +0.12 0	Packaging Unit	Weight in gram/pcs.
SK550-040	300116805	4.0	4.5	2.50	39	9.0	6.5	4.0	100 / 1000	1.71
SK550-050	300116806	5.0	5.5	3.00	41	10.0	7.5	5.0	100 / 1000	2.68
SK550-060	300116807	6.0	6.5	3.40	43	12.0	8.0	6.0	100 / 500	3.61
SK550-070	300116808	7.0	7.5	4.10	38	14.0	9.0	7.0	100 / 500	4.98
SK550-080	300118382	8.0	8.5	4.20	40	15.0	10.5	8.0	100 / 500	6.33
SK550-090	300118383	9.0	9.5	4.50	43	17.0	11.0	9.0	100 / 250	8.23
SK550-100	300118384	10.0	10.5	4.75	45	19.0	12.5	10.0	100 / 250	10.57
SK550-120	300179405	12.0	12.5	5.70	50	24.0	16.5	12.0	50 / 250	16.77

Dimensions in millimeters

PRESSURE PERFORMANCE

Series SK 550 mm	Base Material of the Installation						
	① ETG-100 / 44SMn28 AISI 1144	② C15Pb 1.0403	③ EN-GJL-250 EN 1561	④ EN-GJS-500-7 EN 1563	⑤ AlCu4Mg1 EN AW-2024-T3	⑥ AlMgSiPb EN AW-6012-T6	⑦ G-AlSi7Mg EN AC-42100
ø 4 – 10	1600 bar / 23200 psi 500 bar / 7200 psi					1400 bar / 20300 psi 450 bar / 6500 psi	
ø 12	1600 bar / 23200 psi 400 bar / 5800 psi						

Proof Pressure Test - Ⓢ

Max. Allowable Working Pressure = Nominal Pressure

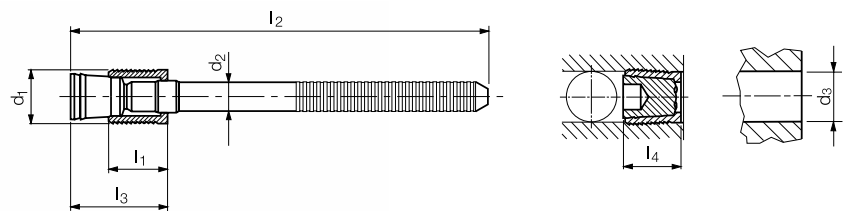

Material:

Sleeve: Case Hardening Steel, Gun Metal-Finish

Mandrel: Heat Treatable Steel, Special Oil Film Lubrication

Important:

See installation instructions on page 92

Installation requirements on page 85



KOENIG EXPANDER® SEALING PLUGS Series SK 552 Long Mandrel

One Piece Construction, Ideal for Automated High Production Requirements
Special Type: With Mandrel 30mm Longer than Standard

3D DATA: www.sfckoenig.com

Part Number	Order Number	d ₁	l ₁	d ₂	l ₂	l ₃ max.	l ₄ max.	d ₃ +0.12 0	Packaging Unit	Weight in gram/pcs.
SK552-040	300119909	4.0	4.5	2.5	69	9.0	6.5	4.0	100 / 1000	2.87
SK552-050	300119911	5.0	5.5	3.0	71	10.0	7.5	5.0	100 / 500	4.32
SK552-060	300119912	6.0	6.5	3.4	73	12.0	8.0	6.0	100 / 500	5.65
SK552-070	300119913	7.0	7.5	4.1	68	14.0	9.0	7.0	100 / 250	8.01
SK552-080	300119914	8.0	8.5	4.2	70	15.0	10.5	8.0	100 / 250	9.60
SK552-090	300119915	9.0	9.5	4.5	73	17.0	11.0	9.0	50 / 100	11.97
SK552-100	300119916	10.0	10.5	4.8	75	19.0	12.5	10.0	50 / 100	14.73

Dimensions in millimeters

PRESSURE PERFORMANCE

Series SK 552 mm	Base Material of the Installation						
	① ETG-100 / 44SMn28 AISI 1144	② C15Pb 1.0403	③ EN-GJL-250 EN 1561	④ EN-GJS-500-7 EN 1563	⑤ AlCu4Mg1 EN AW-2024-T3	⑥ AlMgSiPb EN AW-6012-T6	⑦ G-AlSi7Mg EN AC-42100
Ø 4 – 10	1600 bar / 23200 psi 500 bar / 7200 psi					1400 bar / 20300 psi 450 bar / 6500 psi	

Proof Pressure Test - Ⓢ

Max. Allowable Working Pressure = Nominal Pressure

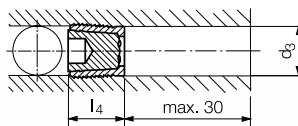
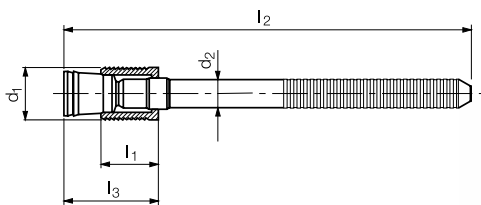

Material:

Sleeve: Case Hardening Steel, Gun Metal-Finish
Mandrel: Heat Treatable Steel, Special Oil Film Lubrication

Important:

See installation instructions on page 92
Installation requirements on page 85



KOENIG EXPANDER® SPACERS Series SK Setting Tools SK552

For Setting KOENIG EXPANDER® SK with Mandrel 30mm Longer than Standard

Typical Applications

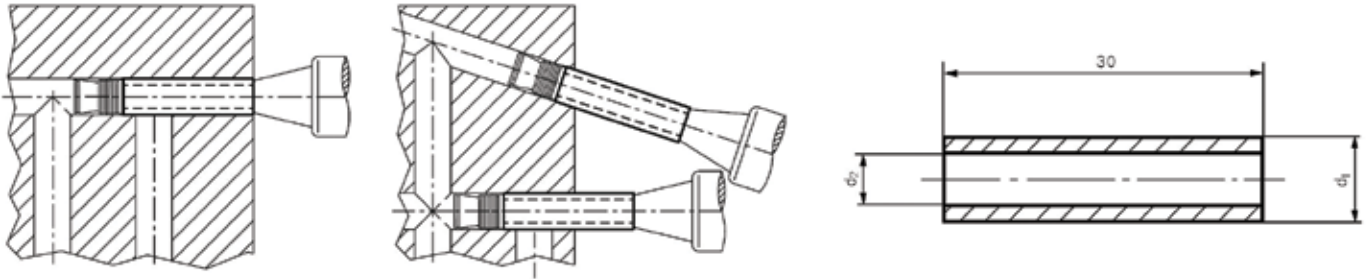

3D DATA: www.sfckoenig.com

Part Number	Order Number	d_1	d_2	Serie SK	Weight in gram/pcs.
4X30-SK	300119923	4.0	2.7	SK 552-040	2
5X30-SK	300119924	5.0	3.2	SK 552-050	3
6X30-SK	300119925	6.0	3.7	SK 552-060	5
7X30-SK	300119926	7.0	4.6	SK 552-070	6
8X30-SK	300119927	8.0	4.8	SK 552-080	8
9X30-SK	300119928	9.0	5.2	SK 552-090	11
10X30-SK	300119929	10.0	5.6	SK 552-100	13

Dimensions in millimeters

Material:

Case Hardening Steel, Case Hardened

RECOMMENDED SETTING EQUIPMENT FOR SERIES SK

KW-008	Hand Lever Tool with Equipment $\varnothing 4 - 6$ mm	See page 78 for more information
EXTOOL-030	Hydraulic/Pneumatic Tool	See page 75 for more information
EXTOOL-040-1	Hydraulic/Pneumatic Tool	See page 76 for more information
EXTOOL-040-2	Hydraulic/Pneumatic Tool	See page 77 for more information





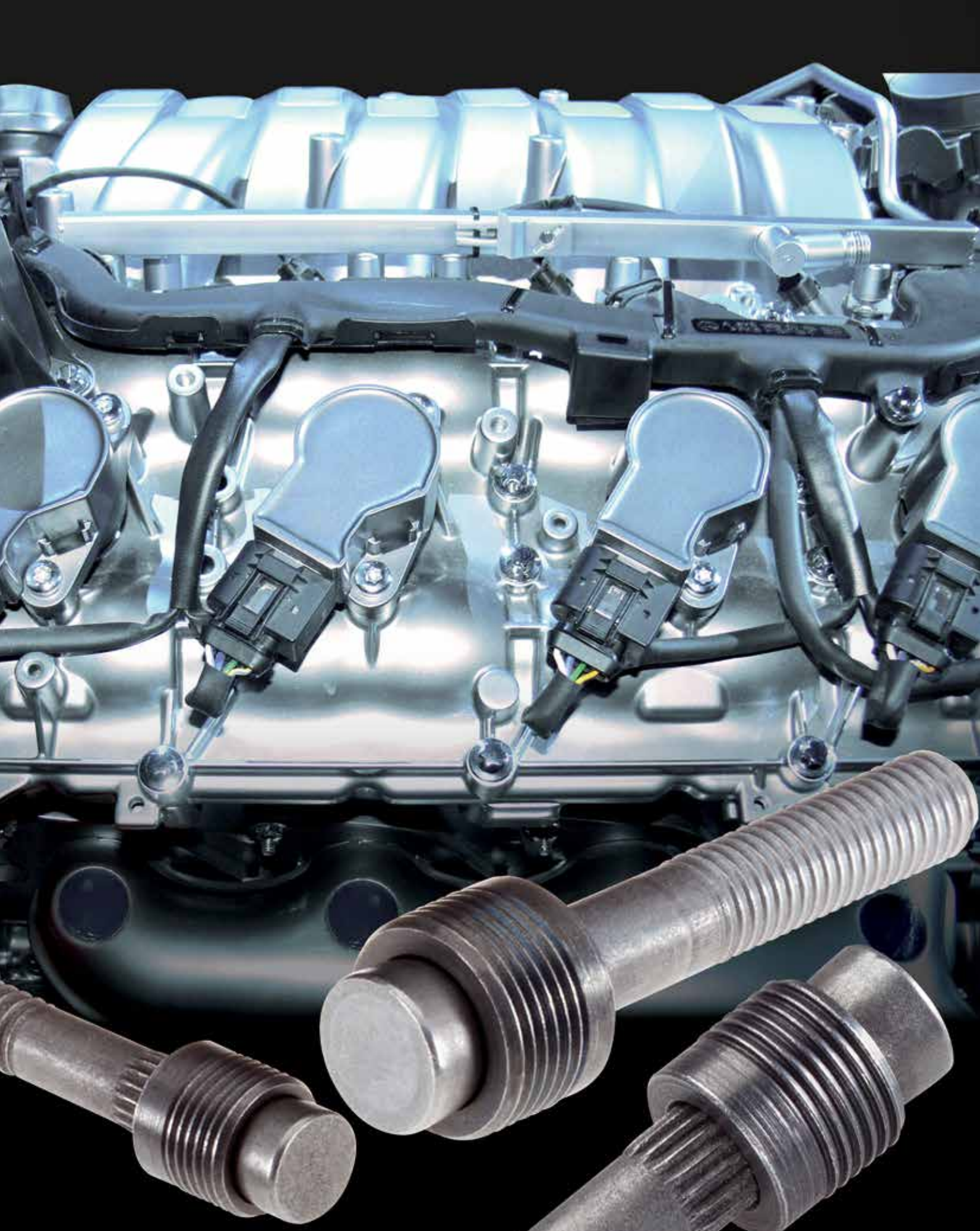

Full Line of Sealing & Flow Control Technologies

KOENIG EXPANDER®

Series LK

Sealing Plugs for Operating Pressures up to 60 bar / 850 psi

- Operating pressures up to 60 bar / 850 psi
- Short installation dimensions
- Liberal manufacturing tolerance 0 / + 0.12 mm
- Direct installation into hydraulic bore
- Purely mechanical sealing through anchorage system
- Installation using convenient processing tools
- Comprehensive product range for Ø 4 – 18mm

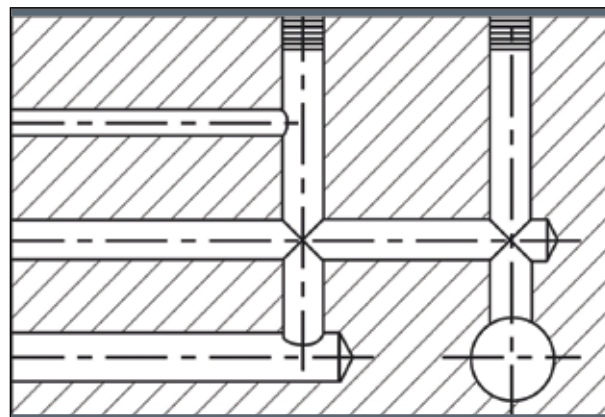
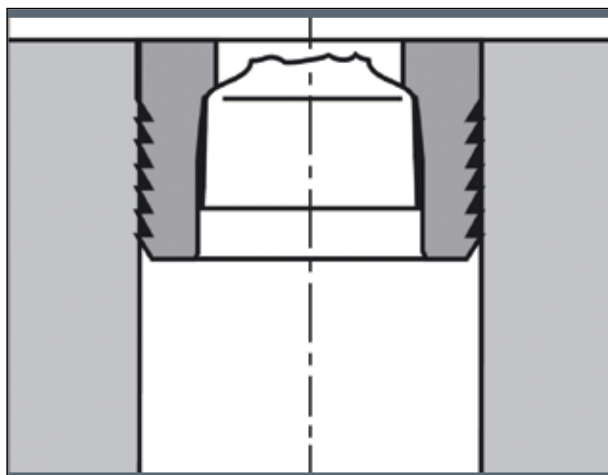

Please inquire with our sales or applications engineers about requirements for special materials or configurations not shown in the catalog.

RECOMMENDED SETTING EQUIPMENT FOR SERIES LK

KW-008	Hand Lever Tool with Equipment ø 4 – 6 mm
EXTOOL-030	Hydraulic/Pneumatic Tool
EXTOOL-040-1	Hydraulic/Pneumatic Tool
EXTOOL-040-2	Hydraulic/Pneumatic Tool

See page 78 for more information
See page 75 for more information
See page 76 for more information
See page 77 for more information



KOENIG EXPANDER® SEALING PLUGS Series LK 600

3D DATA: www.sfckoenig.com

Part Number	Order Number	d ₁	l ₁	d ₂	l ₂	d ₃ +0.12 0	l ₃ max.	l ₄ max.	Packaging Unit	Weight in gram/pcs.
LK 600-040	300162228	4.0	3.7	2.2	33	4.0	5.8	4.0	100 / 1000	1.19
LK 600-050	300162289	5.0	4.5	2.5	36	5.0	7.1	4.8	100 / 1000	1.81
LK 600-060	300162292	6.0	5.0	3.2	36	6.0	7.9	5.5	100 / 1000	2.95
LK 600-070	300162295	7.0	5.5	3.8	32	7.0	8.8	5.8	100 / 500	3.70
LK 600-080	300162299	8.0	6.5	4.3	34	8.0	10.5	7.0	100 / 500	5.26
LK 600-100	300162302	10.0	7.0	4.9	34	10.0	11.0	7.5	100 / 500	7.65

Dimensions in millimeters

PRESSURE PERFORMANCE

Series LK 600 mm	Base Material of the Installation						
	① ETG-100 / 44SMn28 AISI 1144	② C15Pb 1.0403	③ EN-GJL-250 EN 1561	④ EN-GJS-500-7 EN 1563	⑤ AlCu4Mg1 EN AW-2024-T3	⑥ AlMgSiPb EN AW-6012-T6	⑦ G-AlSi7Mg EN AC-42100
∅ 4 – 10	180 bar / 2600 psi 60 bar / 850 psi						

Proof Pressure Test - ⑥

Max. Allowable Working Pressure = Nominal Pressure

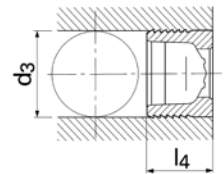
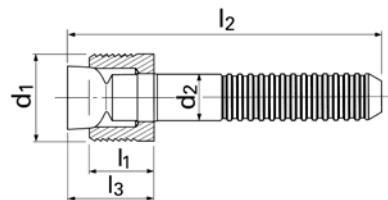

Material:

Sleeve: Stainless Steel, Special Oil Film Lubrication

Mandrel: Stainless Steel, Special Oil Film Lubrication

Important:

See installation instructions on page 93

Installation requirements on page 85



KOENIG EXPANDER® SEALING PLUGS Series LK 950

3D DATA: www.sfckoenig.com

Part Number	Order Number	d ₁	l ₁	d ₂	l ₂	d ₃ *	l ₃ max.	l ₄ max.	Packaging Unit	Weight in gram/pcs.
LK 950-040	300122387	4.0	3.7	2.2	36	4.0	5.5	4.0	100 / 1000	1.26
LK 950-050	300122390	5.0	4.5	3.0	36	5.0	6.9	4.8	100 / 1000	2.28
LK 950-060	300122391	6.0	5.0	3.4	36	6.0	7.4	5.3	100 / 1000	3.12
LK 950-070	300122392	7.0	5.5	4.2	34	7.0	8.0	5.8	100 / 500	4.70
LK 950-080	300122393	8.0	6.5	4.3	34	8.0	9.8	6.8	100 / 500	5.32
LK 950-090	300122394	9.0	6.5	4.7	34	9.0	9.8	6.8	100 / 500	6.53
LK 950-100	300122395	10.0	6.5	5.1	36	10.0	9.8	6.8	100 / 500	8.23
LK 950-120	300122396	12.0	7.5	5.9	36	12.0	11.7	7.8	100 / 500	12.21
LK 950-140	300134275	14.0	8.0	5.9	36	14.0	12.2	9.0	100 / 250	13.98
LK 950-160	300139162	16.0	10.5	5.9	42	16.0	16.0	11.5	100 / 250	21.17
LK 950-180	300159701	18.0	12.0	6.1	46	18.0	18.3	13.0	100 / 250	28.05

Dimensions in millimeters

*In base materials with high hardness or hardened materials:

< 280HB the bore tolerance should be 0 / +0.12

≥ 280HB the bore tolerance should be +0.05 / +0.15

PRESSURE PERFORMANCE

Series LK 950 mm	Base Material of the Installation						
	①	②	③	④	⑤	⑥	⑦
	ETG-100 / 44SMn28 AISI 1144	C15Pb 1.0403	EN-GJL-250 EN 1561	EN-GJS-500-7 EN 1563	AlCu4Mg1 EN AW-2024-T3	AlMgSiPb EN AW-6012-T6	G-AISI7Mg EN AC-42100
Ø 4 – 18	180 bar / 2600 psi 60 bar / 850 psi						

Proof Pressure Test - ⑥

Max. Allowable Working Pressure = Nominal Pressure

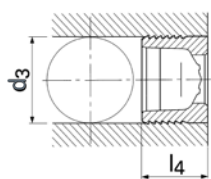
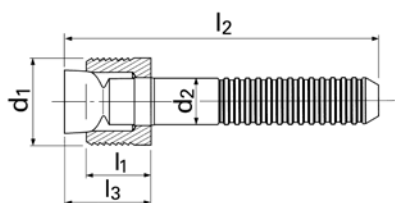

Material:

Sleeve: Case Hardening Steel, Soft Annealed Gun Finish

Mandrel: Steel, Special Oil Film Lubrication

Important:

See installation instructions on page 93

Installation requirements on page 85





Full Line of Sealing & Flow Control Technologies

KOENIG EXPANDER®

Series LP

Sealing Plugs for Operating Pressures up to 60 bar / 850 psi

- Operating pressures up to 60 bar / 850 psi
- Short installation dimensions
- Mechanical sealing using press fit
- Quick installation

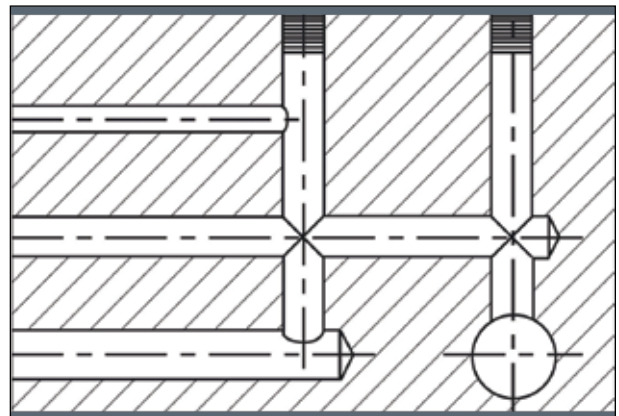
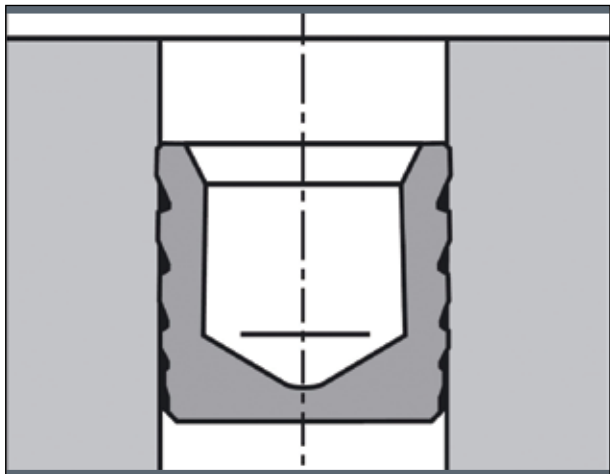

Please inquire with our sales or applications engineers about requirements for special materials or configurations not shown in the catalog.

RECOMMENDED SETTING EQUIPMENT FOR SERIES LP

EXPRESS 3000	Hydropneumatic Table Press	See page 74 for more information
EXPRESS 5000	Hydropneumatic Table Press	See page 74 for more information



KOENIG EXPANDER® SEALING PLUGS Series LP 900

3D DATA: www.sfckoenig.com

Part Number	Order Number	d ₁ Expander	d ₂	l ₁	d ₃ min.	d ₄ +0.1 -0.3	l ₂ min.	Packaging Unit	Weight in gram/pcs.
LP 900-040	300122293	4.40	3.7	5.0	4.55	4.0	7.0	1000 / 10000	0.35
LP 900-050	300122294	5.40	4.7	6.0	5.55	5.0	8.0	1000 / 5000	0.63
LP 900-060	300122295	6.40	5.7	6.0	6.55	6.0	8.5	500 / 2500	0.89
LP 900-070	300122296	7.40	6.7	6.0	7.55	7.0	8.5	500 / 2500	1.20
LP 900-080	300122297	8.45	7.7	7.0	8.60	8.0	9.5	250 / 2000	1.76
LP 900-090	300122298	9.60	9.0	7.5	9.75	9.0	10.0	100 / 1000	2.30
LP 900-100	300122300	10.65	10.0	8.5	10.80	10.0	11.0	100 / 1000	3.20
LP 900-120	300122299	12.75	12.0	9.5	12.90	12.0	12.0	50 / 500	5.03

Dimensions in millimeters

Please inquire with our sales for larger LP 900 model

PRESSURE PERFORMANCE

Series LP 900 mm	Base Material of the Installation						
	① ETG-100 / 44SMn28 AISI 1144	② C15Pb 1.0403	③ EN-GJL-250 EN 1561	④ EN-GJS-500-7 EN 1563	⑤ AlCu4Mg1 EN AW-2024-T3	⑥ AlMgSiPb EN AW-6012-T6	⑦ G-AISI7Mg EN AC-42100
Ø 4 – 12	180 bar / 2600 psi 60 bar / 850 psi						

Proof Pressure Test - ⑥

Max. Allowable Working Pressure = Nominal Pressure

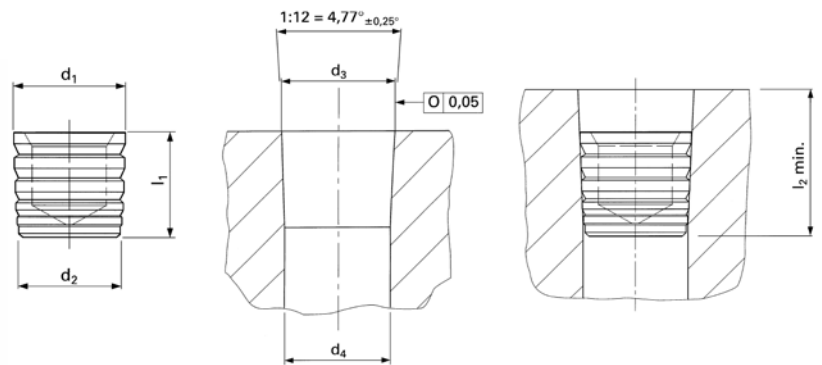

Material:

Free Cutting Steel
Nitrocarburized, Lubricated

Important:

See installation instructions on page 94
Installation requirements on page 85



KOENIG EXPANDER® SETTING TOOLS Series LP

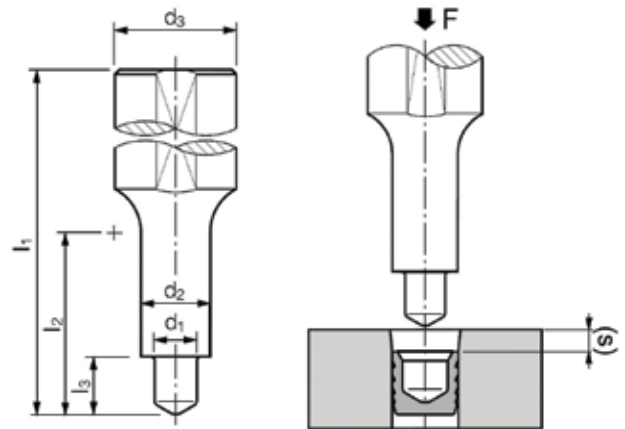

3D DATA: www.sfckoenig.com

Part Number	Order Number	d ₁ Expander	d ₁	d ₂	d ₃ -h9	l ₁	l ₂	l ₃	[s] ~ Ref.	Weight in gram/pcs.
LP 040	300123110	4.40	2.5	3.7	10.0	100	10	3.80	1.0	0.33
LP 050	300123111	5.40	3.1	4.7	10.0	100	15	4.76	1.3	0.61
LP 060	300123112	6.40	3.8	5.7	10.0	100	15	4.79	1.3	0.86
LP 070	300123113	7.40	4.6	6.7	10.0	100	15	4.74	1.5	1.17
LP 080	300123114	8.45	5.3	7.7	10.0	100	20	5.77	1.8	1.71
LP 090	300123115	9.60	6.5	8.7	14.0	100	20	6.23	1.8	2.24
LP 100	300123116	10.65	7.4	9.7	14.0	100	25	6.96	2.0	3.13
LP 120	300123117	12.75	9.1	11.7	14.0	100	25	7.94	2.0	4.93

Dimensions in millimeters

Material:

Tool Steel, Heat Treated, Hardness Approx. HRC 50

RECOMMENDED SETTING EQUIPMENT FOR SERIES LP

EXPRESS 3000	Hydropneumatic Table Press	See page 74 for more information
EXPRESS 5000	Hydropneumatic Table Press	See page 74 for more information



Full Line of Sealing & Flow Control Technologies

KOENIG CHECK VALVE®

Check Valves – Series BF and BR

Max. Working Pressure Differential: 300 bar / 4350 psi in Checked Direction

- Design based on the expansion principal
- Modular concept: Forward Flow Valve (FF) / Reverse Flow Valve (RF)
- Maximum working pressure differential: 300 bar / 4350 psi in checked direction
- Available in a range of standard sizes, cracking pressures and flow rates

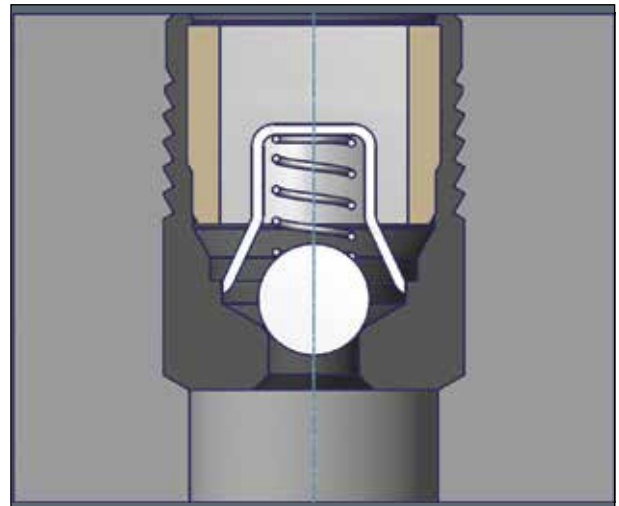
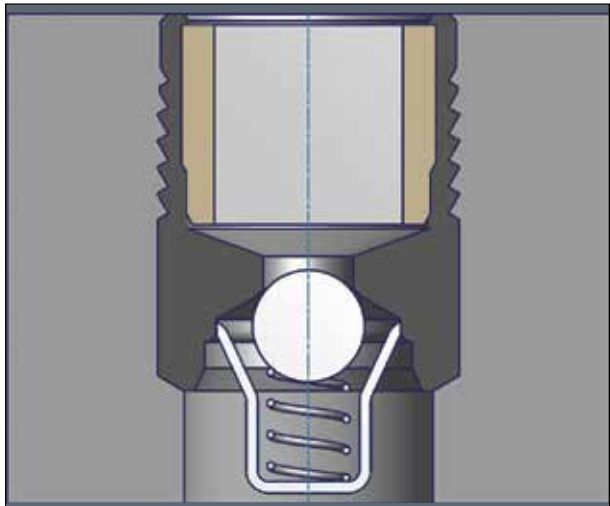

Please inquire with our sales or applications engineers about requirements for special materials or configurations not shown in the catalog.

RECOMMENDED SETTING EQUIPMENT FOR SERIES BF AND BR

EXPRESS 3000

Hydropneumatic Table Press

See page 74 for more information



KOENIG CHECK VALVE® Series BF660080024 Forward Flow

3D DATA: www.sfckoenig.com

Part Number	Order Number	Cracking Pressure (bar)	d ₁	l ₁	d ₂ +0.1 0	(l ₂) ~ Ref.	d ₃	(l ₃) ~ Ref.	d ₄ max.	l ₄ max.	l ₅ min.	0	X ±0.15	(s) ~ Ref.	Pkg. Unit	Gram/ pcs.
BF660080024000	300179735	0 (no spring)	8.0	10.0	8.0	3.8	7.0	13.8	3.8	3.2	10.0	2.4	0.15	4.0	100/ 500	2.86
BF660080024014	300179729	0.14 (±0.05)	8.0	10.0	8.0	3.8	7.0	13.8	3.8	3.2	10.0	2.4	0.15	4.0	100/ 500	2.86
BF660080024040	300179718	0.4 (±0.3)	8.0	10.0	8.0	3.8	7.0	13.8	3.8	3.2	10.0	2.4	0.15	4.0	100/ 500	2.86
BF660080024100	300179500	1.0 (±0.3)	8.0	10.0	8.0	3.8	7.0	13.8	3.8	3.2	10.0	2.4	0.15	4.0	100/ 500	2.86

Dimensions in millimeters

PRESSURE PERFORMANCE

Series BF660080024	Test Material				
	ETG-100 High Strength Steel	GJS-600 Ductile Cast Iron	1.4305 Case Hardened Steel	AA356 Cast Aluminum Alloy	AA2024 (Avional) Aluminum Alloy
MAX. WORKING PRESSURE DIFFERENTIAL IN CHECKED DIRECTION	300 bar / 4350 psi				
MAX. WORKING PRESSURE DIFFERENTIAL IN FLOW DIRECTION	40 bar / 580 psi				

CYCLE TESTING AND LEAKAGE RATE

CYCLE TESTING (OIL HLP46)	1 Mio cycles, 5 Hz, 6 bar
MAX. LEAKAGE RATE (AIR)	15 sccm/min @ 1.72 bar (172 kPa)

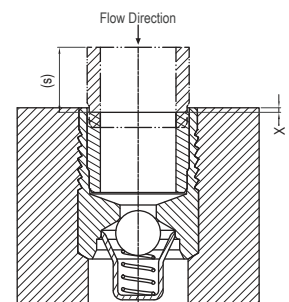
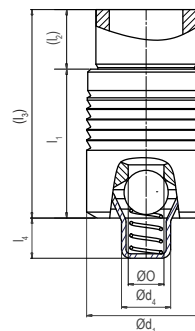
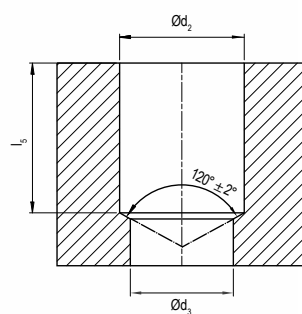

Material:

Sleeve: Stainless Steel, 1.4305 (AISI 303)
 Pin: Stainless Steel, 1.4542 (AISI 630)
 Ball: Bearing Steel, 1.3541 (AISI 420C)
 Spring: Stainless Steel, 1.4310 (AISI 301)
 Cage: Stainless Steel, 1.4310 (AISI 301)

KOENIG CHECK VALVE® Series BR660080024 Reverse Flow

3D DATA: www.sfckoenig.com

Part Number	Order Number	Cracking Pressure [bar]	d_1	l_1	d_2 +0.1 0	(l_2) ~ Ref.	d_3	(l_3) ~ Ref.	l_5 min.	0	X ± 0.15	[s] ~ Ref.	Pkg Unit	Gram/ pcs.
BR660080024000	300179737	0 (no spring)	8.0	10.0	8.0	3.8	7.0	13.8	10.0	2.4	0.15	4.0	100 / 500	2.86
BR660080024014	300179657	0.14 (± 0.05)	8.0	10.0	8.0	3.8	7.0	13.8	10.0	2.4	0.15	4.0	100 / 500	2.86
BR660080024040	300179708	0.4 (± 0.3)	8.0	10.0	8.0	3.8	7.0	13.8	10.0	2.4	0.15	4.0	100 / 500	2.86
BR660080024100	300179503	1.0 (± 0.3)	8.0	10.0	8.0	3.8	7.0	13.8	10.0	2.4	0.15	4.0	100 / 500	2.86

Dimensions in millimeters

PRESSURE PERFORMANCE

Series BR660080024	Test Material				
	ETG-100 High Strength Steel	GJS-600 Ductile Cast Iron	1.4305 Case Hardened Steel	AA356 Cast Aluminum Alloy	AA2024 (Avional) Aluminum Alloy
MAX. WORKING PRESSURE DIFFERENTIAL IN CHECKED DIRECTION	300 bar / 4350 psi				
MAX. WORKING PRESSURE DIFFERENTIAL IN FLOW DIRECTION	40 bar / 580 psi				

CYCLE TESTING AND LEAKAGE RATE

CYCLE TESTING (OIL HLP46)	1 Mio cycles, 5 Hz, 6 bar
MAX. LEAKAGE RATE (AIR)	15 sccm/min @ 1.72 bar (172 kPa)

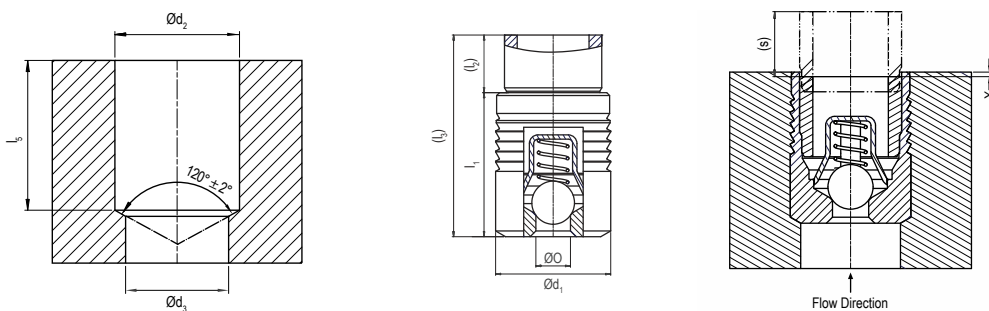

Material:

Sleeve: Stainless Steel, 1.4305 (AISI 303)

Pin: Stainless Steel, 1.4542 (AISI 630)

Ball: Bearing Steel, 1.3541 (AISI 420C)

Spring: Stainless Steel, 1.4310 (AISI 301)

Cage: Stainless Steel, 1.4310 (AISI 301)



KOENIG CHECK VALVE® Series BR055U Reverse Flow

3D DATA: www.sfckoenig.com

Part Number	Order Number	Cracking Pressure [bar]	d ₁	l ₁	d ₂ +0.1 0	(l ₂) ~ Ref.	d ₃	(l ₃) ~ Ref.	l _s min.	0	X ±0.15	(s) ~ Ref.	Pkg Unit	Gram/ pcs.
BR055U000	300179747	0 (no spring)	5.5	7.0	5.5	2.0	4.0	9.0	7.0	1.7	0.15	2.2	100/ 500	0.83
BR055U014	300179627	0.14 (±0.05)	5.5	7.0	5.5	2.0	4.0	9.0	7.0	1.7	0.15	2.2	100/ 500	0.83
BR055U025	300179750	0.25 (±0.1)	5.5	7.0	5.5	2.0	4.0	9.0	7.0	1.7	0.15	2.2	100/ 500	0.83
BR055U040	300179752	0.4 (±0.3)	5.5	7.0	5.5	2.0	4.0	9.0	7.0	1.7	0.15	2.2	100/ 500	0.83
BR055U050	300179804	0.5 (±0.3)	5.5	7.0	5.5	2.0	4.0	9.0	7.0	1.7	0.15	2.2	100/ 500	0.83
BR055U100	300179754	1.0 (±0.3)	5.5	7.0	5.5	2.0	4.0	9.0	7.0	1.7	0.15	2.2	100/ 500	0.83
BR055U200	300179629	2.0 (±0.3)	5.5	7.0	5.5	2.0	4.0	9.0	7.0	1.7	0.15	2.2	100/ 500	0.83

Dimensions in millimeters

PRESSURE PERFORMANCE

Series BR055U	Test Material				
	ETG-100 High Strength Steel	GJS-600 Ductile Cast Iron	1.4305 Case Hardened Steel	AA356 Cast Aluminum Alloy	AA2024 (Avional) Aluminum Alloy
MAX. WORKING PRESSURE DIFFERENTIAL IN CHECKED DIRECTION	300 bar / 4350 psi				
MAX. WORKING PRESSURE DIFFERENTIAL IN FLOW DIRECTION	40 bar ₁₎ / 580 psi				

1) Version BR055U014 max. 30 bar / 440 psi in flow direction

CYCLE TESTING AND LEAKAGE RATE

CYCLE TESTING (OIL HLP46)	1 Mio cycles, 5 Hz, 6 bar
MAX. LEAKAGE RATE (AIR)	15 sccm/min @ 1.72 bar (172 kPa)

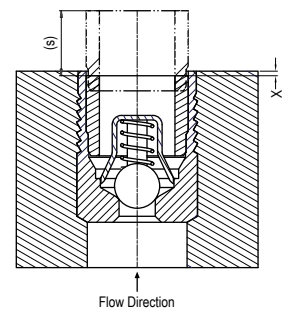
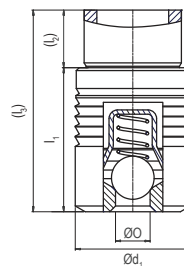
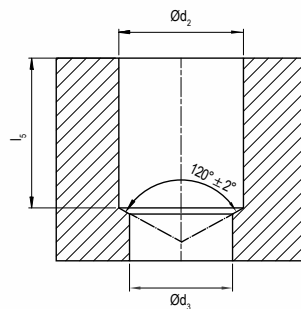

Material:

Sleeve: Stainless Steel, 1.4305 (AISI 303)
 Pin: Stainless Steel, 1.4021 (AISI 420)
 Ball: Bearing Steel, 1.3541 (AISI 420C)
 Spring: Stainless Steel, 1.4310 (AISI 301)
 Cage: Stainless Steel, 1.4310 (AISI 301)

KOENIG CHECK VALVE® SETTING TOOL Series BF and BR

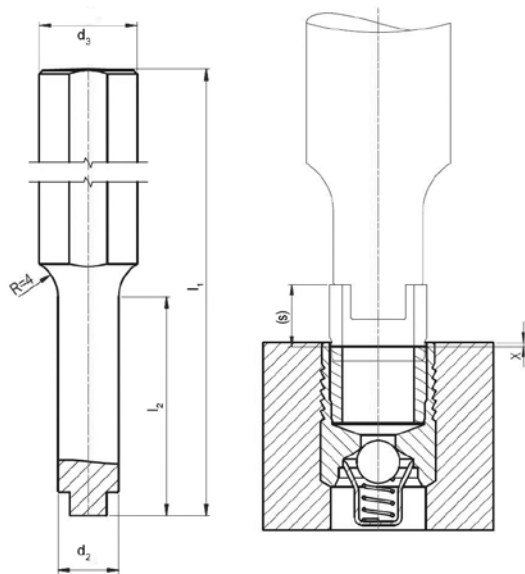

Part Number	Order Number	BF-R	d ₃ h9	l ₁	d ₂ ±0.1	l ₂	X ±0.15	(s) ~ Ref.	Weight in gram/pcs.
BF-R 055U	300179819	5.5	10.0	100	4.0	15.0	0.15	2.2	50
BF-R 080	300179556	8.0	10.0	100	6.2	22.4	0.15	4.0	51

Dimensions in millimeters

Material:

Tool Steel, Heat Treated, Hardness Approx. HRC 50

RECOMMENDED SETTING EQUIPMENT FOR SERIES BF AND BR

EXPRESS 3000

Hydropneumatic Table Press

See page 74 for more information



Full Line of Sealing & Flow Control Technologies

KOENIG RESTRICTOR®

Orifices – Series RE, RT and RP

- Restrictors in threaded or expansion styles, metric or standard dimensions
- Can be used with fluids or gases
- Standard restrictors in 300 series stainless steel
- Orifices can be calculated to achieve desired flow rates
- Threaded style plugs can easily be changed out to alter flow rates
- Expansion style plugs are tamper resistant

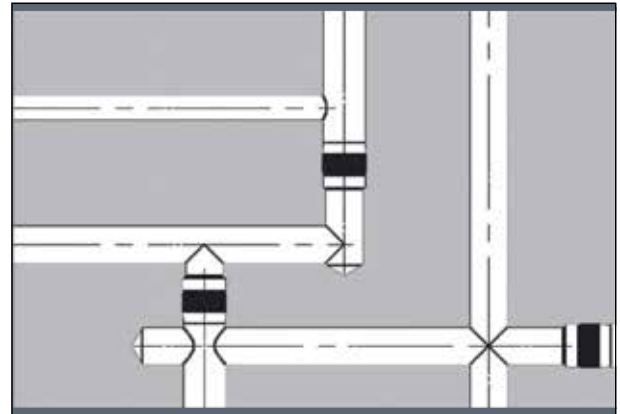
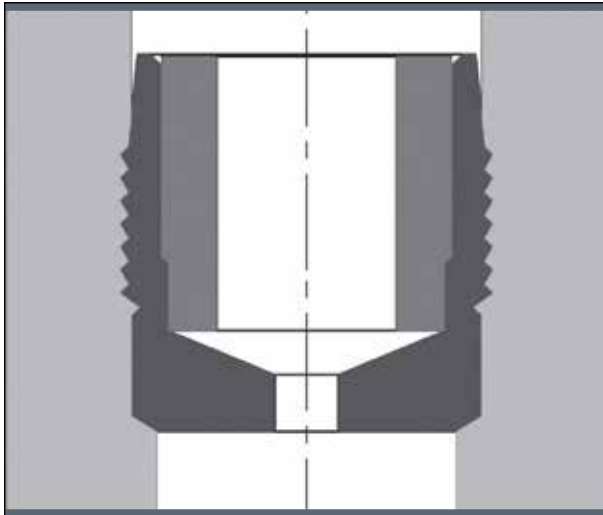

Please inquire with our sales or applications engineers about requirements for special materials or configurations not shown in the catalog.

RECOMMENDED SETTING EQUIPMENT FOR SERIES RE

EXPRESS 3000	Hydropneumatic Table Press	See page 74 for more information
EXPRESS 5000	Hydropneumatic Table Press	See page 74 for more information



KOENIG RESTRICTOR® ORIFICE RESTRICTORS Series RE

3D DATA: www.sfckoenig.com

Part Number	d_1	l_1	(l_2) ~ Ref.	\varnothing ± 0.025 Orifice Diameter	d_2 $+0.10$ 0	l_3 min.	d_3 max.	(s) ~ Ref.	x ± 0.3	Packaging Unit
RE-040-XXX	4.0	4.0	6.0	0.40 - 1.27	4.0	3.9	3.3	2.0	0.0	100 / 1000
RE-050-XXX	5.0	5.5	8.2	0.40 - 1.91	5.0	5.4	4.3	2.7	0.0	100 / 1000
RE-060-XXX	6.0	6.5	9.9	0.40 - 2.54	6.0	6.4	5.3	3.4	0.0	100 / 1000
RE-070-XXX	7.0	7.5	11.6	0.40 - 3.30	7.0	7.4	6.2	4.1	0.0	100 / 1000
RE-080-XXX	8.0	8.5	13.3	0.40 - 3.81	8.0	8.4	7.2	4.8	0.0	100 / 1000
RE-090-XXX	9.0	10.0	15.5	0.40 - 4.32	9.0	9.9	8.2	5.5	0.0	100 / 1000
RE-100-XXX	10.0	11.0	17.1	0.40 - 4.95	10.0	10.9	9.2	6.1	0.0	50 / 250
RE-120-XXX	12.0	13.0	20.5	0.40 - 6.10	12.0	12.9	11.0	7.5	0.0	50 / 250
RE-140-XXX	14.0	15.0	23.7	0.40 - 7.11	14.0	14.6	13.0	8.7	0.0	25 / 125

Dimensions in millimeters

The weight depending on the orifice diameter

Not all items in stock – production MOQ & lead times may apply

To calculate orifice diameter/length please refer to page 104

PRESSURE PERFORMANCE

Series RE mm	Base Material of the Installation			
	AISI 1144 High Strength Steel	Dura Bar 65-45-12 Ductile Cast Iron	AA 2024 Aluminum Alloy	A356 Cast Aluminum Alloy
$\varnothing 4$	120 bar / 1740 psi			100 bar / 1450 psi
$\varnothing 5$	180 bar / 2610 psi			150 bar / 2175 psi
$\varnothing 6$	210 bar / 3045 psi			150 bar / 2175 psi
$\varnothing 7-8$	210 bar / 3045 psi			180 bar / 2610 psi
$\varnothing 9-14$	Please Contact Us for Details			

Proof Pressure Test - ®

Max. Allowable Working Pressure = Nominal Pressure

Please note these recommendations are generally conservative and higher working pressures are possible in some applications. Please contact your local applications engineer with any questions.

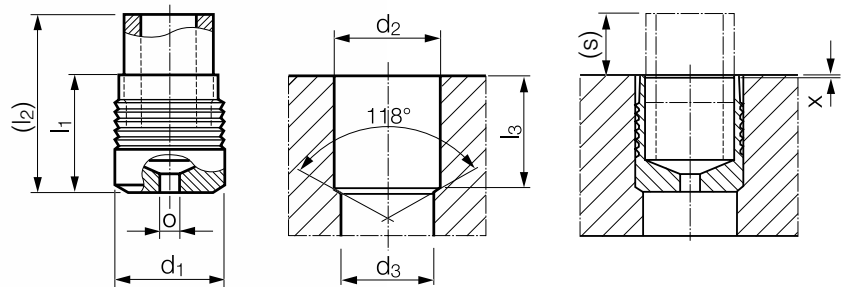

Material:

Stainless Steel AISI 303/304

Part Number Key:

XXX is orifice diameter in hundredths of a millimeter, for example 127 for 1.27mm, with the decimal always in the same location

KOENIG RESTRICTOR® ORIFICE RESTRICTORS Series RE Inch

3D DATA: www.sfckoenig.com

Part Number	d_1	l_1	(l_2) ~ Ref.	\varnothing ± 0.001 Orifice Diameter	d_2 $+0.004$ 0	l_3 min.	d_3 max.	(s) ~ Ref.	x ± 0.01	Packaging Unit
RE-156-XXX	0.156	0.158	0.24	0.016 - 0.050	0.1563	0.154	0.130	0.083	0.0	100 / 1000
RE-187-XXX	0.187	0.217	0.31	0.016 - 0.070	0.1875	0.213	0.160	0.093	0.0	100 / 1000
RE-218-XXX	0.218	0.217	0.33	0.016 - 0.085	0.2188	0.213	0.190	0.113	0.0	100 / 1000
RE-250-XXX	0.250	0.256	0.40	0.016 - 0.105	0.2500	0.252	0.220	0.144	0.0	100 / 1000
RE-281-XXX	0.281	0.296	0.46	0.016 - 0.130	0.2813	0.292	0.250	0.164	0.0	100 / 1000
RE-312-XXX	0.312	0.335	0.52	0.016 - 0.150	0.3125	0.331	0.281	0.185	0.0	100 / 1000
RE-343-XXX	0.343	0.394	0.60	0.016 - 0.160	0.3438	0.390	0.312	0.206	0.0	50 / 250
RE-375-XXX	0.375	0.394	0.62	0.016 - 0.180	0.3750	0.390	0.343	0.226	0.0	50 / 250
RE-406-XXX	0.406	0.434	0.67	0.016 - 0.195	0.4063	0.430	0.375	0.236	0.0	50 / 250
RE-437-XXX	0.437	0.512	0.77	0.016 - 0.220	0.4375	0.508	0.406	0.258	0.0	25 / 100
RE-468-XXX	0.468	0.512	0.81	0.016 - 0.240	0.4688	0.508	0.437	0.298	0.0	25 / 100
RE-562-XXX	0.562	0.591	0.94	0.016 - 0.290	0.5625	0.580	0.510	0.349	0.0	25 / 100

Dimensions in inches

The weight depending on the orifice diameter

Not all items in stock – production MOQ & lead times may apply

To calculate orifice diameter/length please refer to page 105

PRESSURE PERFORMANCE

Series RE Inch	Base Material of the Installation			
	AISI 1144 High Strength Steel	Dura Bar 65-45-12 Ductile Cast Iron	AA 2024 Aluminum Alloy	A356 Cast Aluminum Alloy
\varnothing 0.156	120 bar / 1740 psi			100 bar / 1450 psi
\varnothing 0.187	180 bar / 2610 psi			150 bar / 2175 psi
\varnothing 0.218– \varnothing 0.250	210 bar / 3045 psi			150 bar / 2175 psi
\varnothing 0.281– \varnothing 0.312	210 bar / 3045 psi			180 bar / 2610 psi
\varnothing 0.343– \varnothing 0.562	Please Contact Us for Details			

Proof Pressure Test - Ⓢ

Max. Allowable Working Pressure = Nominal Pressure

Please note these recommendations are generally conservative and higher working pressures are possible in some applications. Please contact your local applications engineer with any questions.

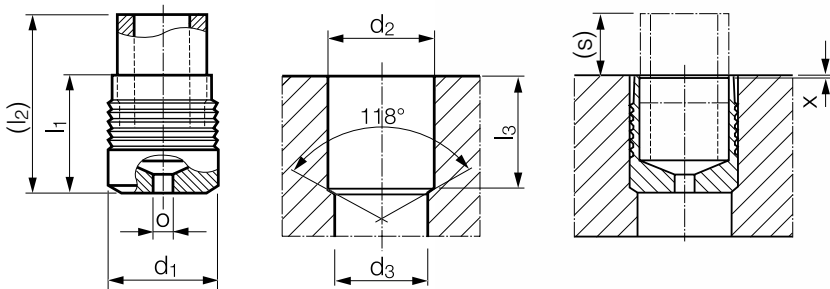

Material:

Stainless Steel AISI 303/304

Part Number Key:

XXX is orifice diameter in thousandths of an inch, for example 050 for 0.050, with the decimal always in the same location



KOENIG RESTRICTOR® SETTING TOOLS Series RE

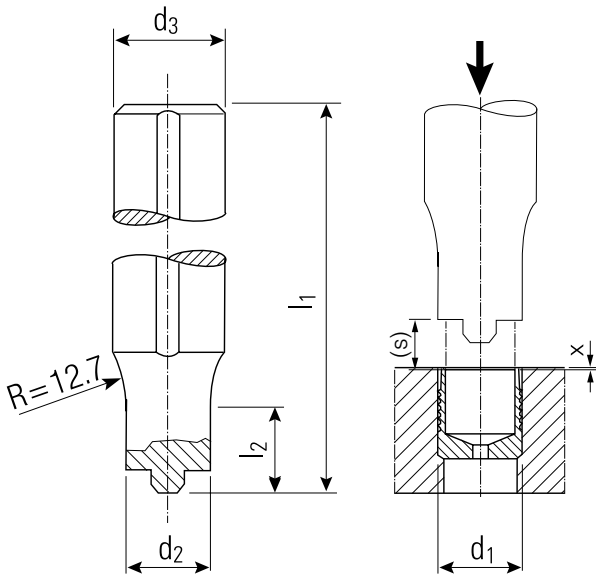

3D DATA: www.sfckoenig.com

Part Number	d ₁ Series RE	d ₁ Series RE	d ₃ ±0.20	l ₁	d ₂	l ₂	(s) ~ Ref.	x ±0.30	Weight in gram/pcs.
HT-REM-040	RE-040-XXX	RE-156-XXX	9.53	127	3.61	7.62	2.0	0.0	70
HT-REM-050	RE-050-XXX	-	9.53	127	4.78	12.70	2.7	0.0	70
HT-REM-060	RE-060-XXX	-	9.53	127	5.79	15.24	3.4	0.0	70
HT-REM-070	RE-070-XXX	RE-281-XXX	9.53	127	6.78	20.32	4.1	0.0	70
HT-REM-080	RE-080-XXX	RE-312-XXX	9.53	127	7.57	33.02	4.8	0.0	70
HT-REM-090	RE-090-XXX	-	12.70	127	8.36	38.10	5.5	0.0	70
HT-REM-100	RE-100-XXX	RE-406-XXX	12.70	127	9.78	38.10	6.1	0.0	70
HT-REM-120	RE-120-XXX	RE-468-XXX	12.70	127	11.68	38.10	7.5	0.0	70
HT-REM-140	RE-140-XXX	-	15.88	127	13.69	45.72	8.7	0.0	70

Dimensions in millimeters

Not all items in stock – production MOQ & lead times may apply

Material:

Tool Steel, Heat Treated, Hardness Approx. HRC 50

RECOMMENDED SETTING EQUIPMENT FOR SERIES RE

EXPRESS 3000	Hydropneumatic Table Press	See page 74 for more information
EXPRESS 5000	Hydropneumatic Table Press	See page 74 for more information

KOENIG RESTRICTOR® SETTING TOOLS Series RE Inch

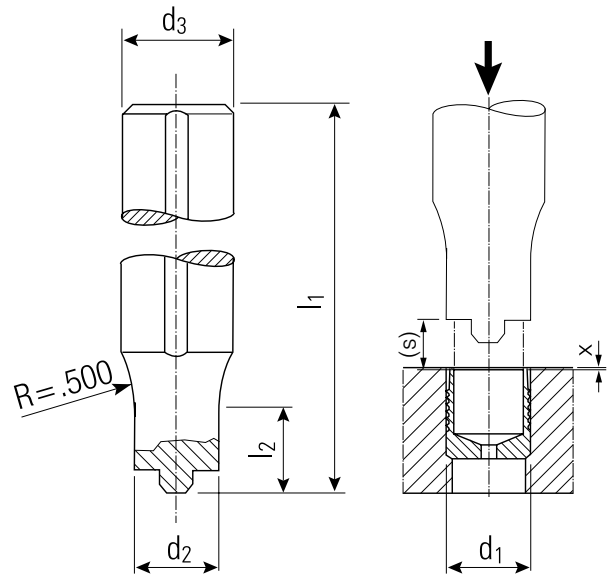

3D DATA: www.sfckoenig.com

Part Number	d ₁ Series RE	d ₁ Series RE	d ₃ ±0.008	l ₁	d ₂	l ₂	(s) ~ Ref.	x ±0.01	Weight in gram/pcs.
HT-REM-040	RE-156-XXX	RE-040-XXX	0.375	5.0	0.142	0.3	0.08	0.0	70
HT-REI-187	RE-187-XXX	-	0.375	5.0	0.174	0.5	0.09	0.0	70
HT-REI-218	RE-218-XXX	-	0.375	5.0	0.205	0.6	0.11	0.0	70
HT-REI-250	RE-250-XXX	-	0.375	5.0	0.236	0.6	0.14	0.0	70
HT-REM-070	RE-281-XXX	RE-070-XXX	0.375	5.0	0.267	0.8	0.16	0.0	70
HT-REM-080	RE-312-XXX	RE-080-XXX	0.375	5.0	0.298	1.3	0.19	0.0	70
HT-REI-343	RE-343-XXX	-	0.500	5.0	0.330	1.5	0.21	0.0	70
HT-REI-375	RE-375-XXX	-	0.500	5.0	0.361	1.5	0.23	0.0	70
HT-REM-100	RE-406-XXX	RE-100-XXX	0.500	5.0	0.385	1.5	0.24	0.0	70
HT-REI-437	RE-437-XXX	-	0.500	5.0	0.434	1.5	0.26	0.0	70
HT-REM-120	RE-468-XXX	RE-120-XXX	0.500	5.0	0.460	1.5	0.30	0.0	70
HT-REI-562	RE-562-XXX	-	0.625	5.0	0.549	1.8	0.35	0.0	70

Dimensions in inches

Not all items in stock – production MOQ & lead times may apply

Material:

Tool Steel, Heat Treated, Hardness Approx. HRC 50

RECOMMENDED SETTING EQUIPMENT FOR SERIES RE

EXPRESS 3000	Hydropneumatic Table Press	See page 74 for more information
EXPRESS 5000	Hydropneumatic Table Press	See page 74 for more information

KOENIG RESTRICTOR® ORIFICE RESTRICTORS Series RT

Part Number	Screw Thread Size	± 0.025 Orifice Diameter	(d_1) ~ Ref.	(l_1) ~ Ref.	d_2	l_3 min.	Hex Key Size	Packaging Unit
RT-040-XXX	M4x0.7	0.51 - 0.89	4.0	4.0	M4x0.7	4.0	2.0	100 / 1000
RT-050-XXX	M5x0.8	0.51 - 1.40	5.0	5.0	M5x0.8	5.0	2.5	100 / 1000
RT-060-XXX	M6x1.0	0.51 - 1.91	6.0	6.0	M6x1.0	6.0	3.0	100 / 1000
RT-080-XXX	M8x1.25	0.51 - 2.92	8.0	8.0	M8x1.25	8.0	4.0	100 / 1000
RT-100-XXX	M10x1.5	0.51 - 3.94	10.0	10.0	M10x1.5	10.0	5.0	50 / 250
RT-120-XXX	M12x1.75	0.51 - 4.95	12.0	12.0	M12x1.75	12.0	6.0	50 / 250

Dimensions in millimeters

Not all items in stock – production MOQ & lead times may apply

The weight depending on the orifice diameter

To calculate orifice diameter/length please refer to page 104

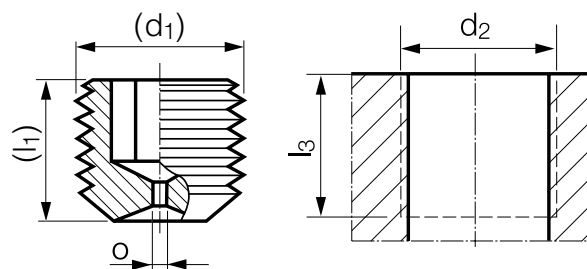

Material:

Stainless Steel AISI Series 300

Part Number Key:

XXX is orifice diameter in hundredths of a millimeter, for example 127 for 1.27mm, with the decimal always in the same location



KOENIG RESTRICTOR® ORIFICE RESTRICTORS Series RT Inch

Part Number	Screw Thread Size	± 0.001 Orifice Diameter	(d_1) ~ Ref.	(l_1) ~ Ref.	d_2	l_3 min.	Hex Key Size	Packaging Unit
RT-164-XXX	8-32	0.020 - 0.035	0.164	0.188	8 - 32	0.188	5/64	100 / 1000
RT-190-XXX	10-32	0.020 - 0.050	0.190	0.188	10 - 32	0.188	3/32	100 / 1000
RT-250-XXX	1/4"-28	0.020 - 0.085	0.250	0.250	1/4" - 28"	0.250	1/8	100 / 1000
RT-312-XXX	5/16"-24	0.020 - 0.115	0.312	0.313	5/16" - 24"	0.313	5/32	100 / 1000
RT-375-XXX	3/8"-24	0.020 - 0.145	0.375	0.375	3/8" - 24"	0.375	3/16	50 / 250
RT-437-XXX	7/16"-20	0.020 - 0.175	0.437	0.375	7/16" - 20"	0.375	7/32	25 / 100
RT-500-XXX	1/2"-20	0.020 - 0.210	0.500	0.500	1/2" - 20"	0.500	1/4	25 / 100

Dimensions in inches

Not all items in stock – production MOQ & lead times may apply

The weight depending on the orifice diameter

To calculate orifice diameter/length please refer to page 105

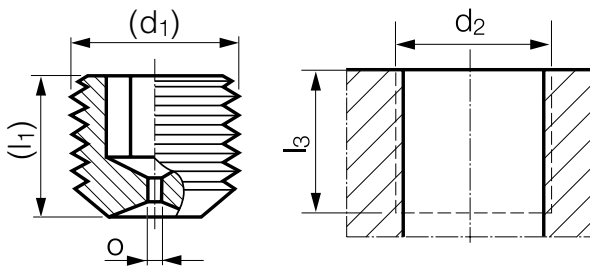

Material:

Stainless Steel AISI Series 300

Part Number Key:

XXX is orifice diameter in thousandths of a inch, for example 050 for 0.050, with the decimal always in the same location



KOENIG RESTRICTOR® ORIFICE RESTRICTORS

Series Threaded Type, NPTF Pipe Plug per SAE J531

Part Number	Screw Thread Size	± 0.001 Orifice Diameter	(d_1) ~ Ref.	(l_1) ~ Ref.	d_2	l_3 min.	Hex Key Size	Packaging Unit
RP-062-XXX	1/16"-27 NPTF	0.020 - 0.115	0.312	0.300	1/16" - 27 NPTF	0.300	5/32	100 / 1000
RP-125-XXX	1/8"-27 NPTF	0.020 - 0.145	0.405	0.300	1/8" - 27 NPTF	0.300	3/16	100 / 1000
RP-250-XXX	1/4"-18 NPTF	0.020 - 0.210	0.540	0.450	1/4" - 18 NPTF	0.450	1/4	100 / 1000
RP-375-XXX	3/8"-18NPTF	0.020 - 0.270	0.675	0.450	3/8" - 18 NPTF	0.450	5/16	50 / 250

Dimensions in inches

Not all items in stock – production MOQ & lead times may apply

The weight depending on the orifice diameter

To calculate orifice diameter/length please refer to pages 104-105

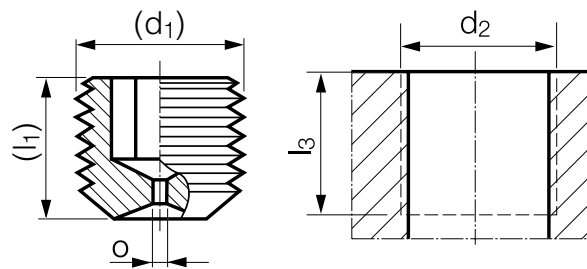

Material:

300 Series Stainless Steel

Part Number Key:

XXX is orifice diameter in thousandths of a inch, for example 050 for 0.050, with the decimal always in the same location



KOENIG RESTRICTOR® ORIFICE RESTRICTORS

Series Threaded Type, NPTF Pipe Plug per SAE J531

Part Number	Screw Thread Size	± 0.001 Orifice Diameter	(d_1) ~ Ref.	(l_1) ~ Ref.	d_2	l_3 min.	Hex Key Size	Packaging Unit
RPB-062-XXX	1/16"-27 NPTF	0.020 - 0.115	0.312	0.300	1/16" - 27 NPTF	0.300	5/32	100 / 1000
RPB-125-XXX	1/8"-27 NPTF	0.020 - 0.145	0.405	0.300	1/8" - 27 NPTF	0.300	3/16	100 / 1000
RPB-250-XXX	1/4"-18 NPTF	0.020 - 0.210	0.540	0.450	1/4" - 18 NPTF	0.450	1/4	100 / 1000
RPB-375-XXX	3/8"-18NPTF	0.020 - 0.270	0.675	0.450	3/8" - 18 NPTF	0.450	5/16	50 / 250

Dimensions in inches

Not all items in stock – production MOQ & lead times may apply

The weight depending on the orifice diameter

To calculate orifice diameter/length please refer to pages 104-105

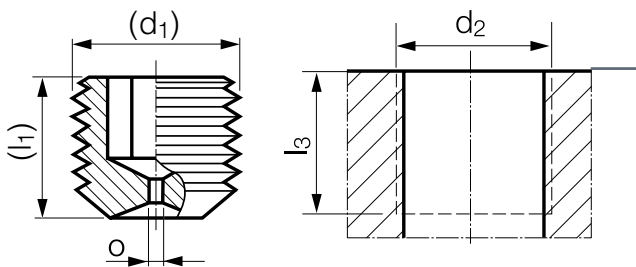

Material:

Brass

Part Number Key:

XXX is orifice diameter in thousandths of a inch, for example 050 for 0.050, with the decimal always in the same location



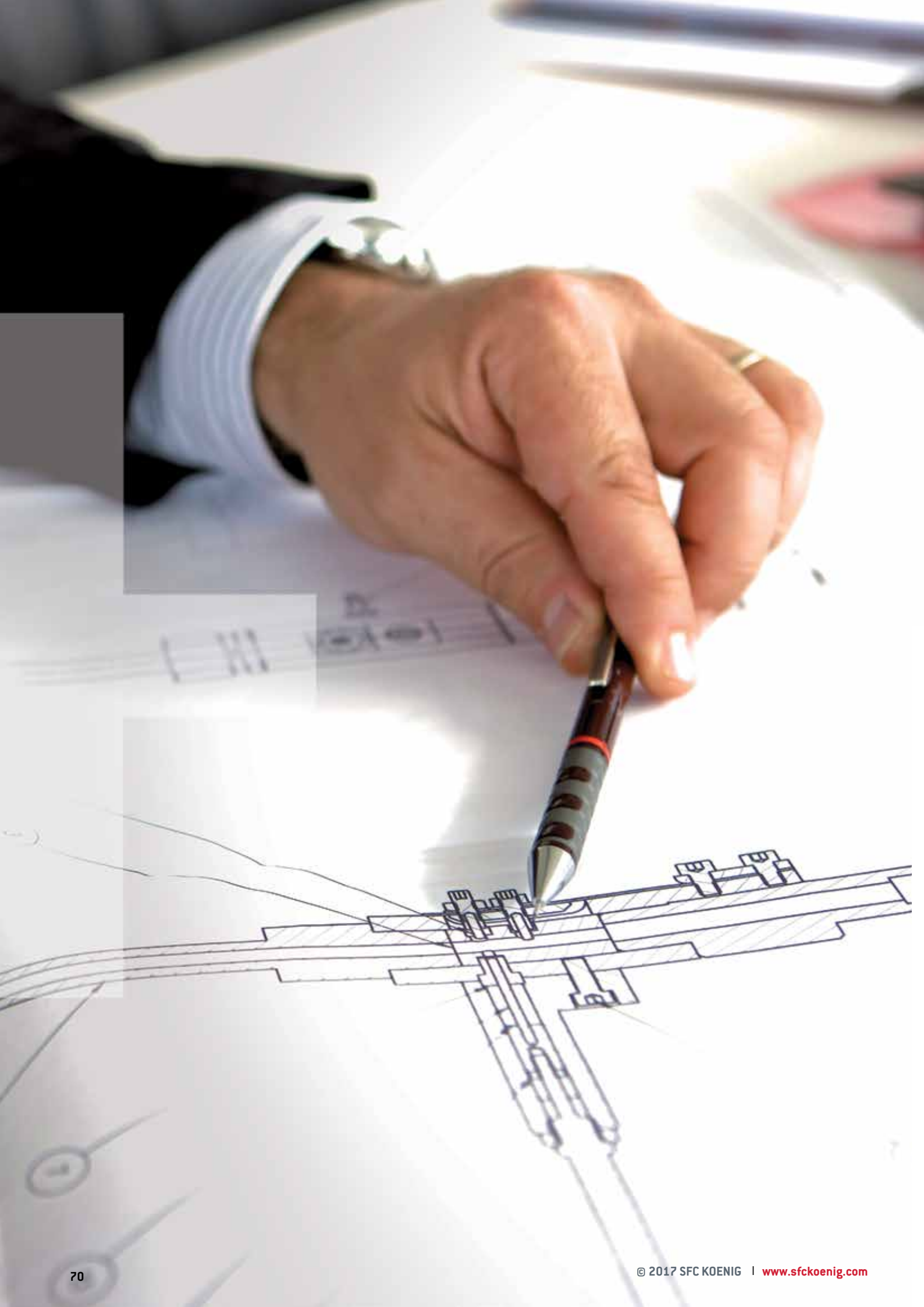

Special Orders

In addition to our standard product line, SFC KOENIG can provide customized parts and unique solutions specially designed for your installation.

Our in-house engineering staff is available to assist you with your needs. With decades of expertise in sealing we meet even the most unique requirements, producing parts that are tailored to your exact application. Our team includes some of the industry's most experienced engineers and manufacturing personnel, and we deliver the solutions others cannot.

From material to size to operation, we are able to customize our components to meet unique installations. With over 3 billion parts delivered to customers around the world, we are experts in sealing and flow control, and are ready to apply that knowledge to your order.

SFC KOENIG maintains failure rates less than 1 part per million, delivering reliable solutions with unmatched consistency. Our engineering expertise, quality controls and efficient manufacturing operations are designed to produce the highest quality parts for each customer's requirements.

SFC KOENIG brings more than 80 years of success to the design processes. From the initial design consultation to testing, production and process integration, we are ready to work with you to solve your unique sealing and flow control challenge.





Full Line of Sealing & Flow Control Technologies

SETTING TOOL EQUIPMENT

Setting Equipment for All Series

- Express 3000 / Hydropneumatic Table Press
- Express 5000 / Hydropneumatic Table Press
- EXT00L 030, 040-1 and 040-2 / Hydraulic / Pneumatic Tool with Mandrel Collection Device
- KW-008 - Hand Lever Tool with Equipment \varnothing 4 – 6 mm



SETTING TOOLS EXPRESS 3000/5000

Hydropneumatic Table Press for Series MB / CV / LP / RE with Force and Distance Control

Hydropneumatic setting tool for the installation of KOENIG EXPANDER®. Quick tool change avoids long changeover times. The required working stroke is preprogrammed and can be retrieved by the Expander type to be processed (max. 32 memory locations). In addition, the working stroke is referenced for each individual Expander, which guarantees high process stability and quality. The press is force and distance controlled; an RS232 interface can be used to trace corresponding data on the customer's computer for later processing. The required software is included in the scope of delivery.

EXPRESS 3000 –For the installation of KOENIG EXPANDER Series MB, CV and LP from Ø 3 – 10mm [.093” – .375” inch] and Series RE from Ø 4 – 10mm [.156” – .375” inch].

EXPRESS 5000 –For the installation of KOENIG EXPANDER Series MB and CV Ø 12 – 22mm [.406” – .875” inch], Series LP for Ø 12mm and for the Series RE from Ø 12 – 14mm [.406” – .562”].

SETTING TOOL DATA			
	EXPRESS 3000		EXPRESS 5000
HEIGHT	approx. 1360 mm	HEIGHT	approx. 1470 mm
WIDTH	approx. 340 mm (max. 530 mm)	WIDTH	approx. 400 mm (max. 580 mm)
DEPTH	approx. 495 mm	DEPTH	approx. 535 mm
TABLE (WIDTH X DEPTH)	220 x 160 mm	TABLE (WIDTH X DEPTH)	300 x 190 mm
WEIGHT	approx. 140 kg	WEIGHT	approx. 190 kg
COMPRESSIVE FORCE	30 kN (max force 29.5 kN at 6 bar)	COMPRESSIVE FORCE	50 kN (max force 52.5 kN at 6 bar)
WORKING STROKE	10 mm (within the cylinder ram)	WORKING STROKE	15 mm (within the cylinder ram)
WORKING SPEED	40 mm/sec (max. possible at 6 bar)	WORKING SPEED	30 mm/sec (max. possible at 6 bar)



SETTING TOOL DATA	
EXPRESS 3000 and EXPRESS 5000	
WORKING AREA (HEIGHT)	250 mm (working height between table top and cylinder, without setting tool)
WORKING AREA (DEPTH)	200 mm (center-line spacing between cylinder and C frame)
CYLINDER RAM	60 mm
OPERATING VOLTAGE	230 V/110 V, Automatic switchover to corresponding power supply
OPERATION	VISUAL POINT terminal with QVGA graphic display
FORCE / DISTANCE CONTROL	Sensor adjusted with SIT reference sensor
SOFTWARE	WINSCOPE Software for connecting to a PC

SETTING TOOL EXT00L-030

Hydropneumatic Tool for Series SK / LK with Mandrel Collection Device

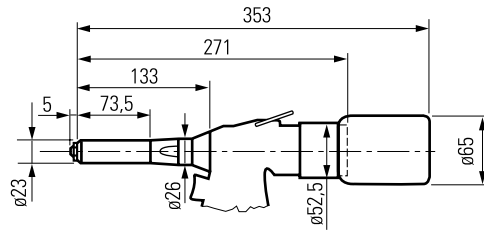

3D DATA: www.sfckoenig.com

Type	EXT00L-030	EXT00L-030
Serie	SK	LK
Order Number	300160392	300160392
Weight	2,5 kg	2,5 kg
Pull force at 7 bar	19 kN	19 kN
Working stroke	25 mm	25 mm
Air supply pressure (min.- max.)	5-7 bar	5-7 bar
Air consumption at 5-6 bar	3,5 l	3,5 l
Noise level	< 75 dB(A)	< 75 dB(A)
Cycle time	2.0 s	2.0 s
* Nosepiece (not included) Expander Ø 4.0	-	361013304110
Nosepiece (not included) Expander Ø 4.0	361013304100	361013304100
Nosepiece (not included) Expander Ø 5.0	361013305100	361013305100
Nosepiece (not included) Expander Ø 6.0	361013306100	361013306100
Jaws Expander Ø 4.0 - 6.0	361130400504	361130400504
Jaws case Expander Ø 4.0 - 6.0	321120000012	321120000012
Jaws pusher Expander Ø 4.0 - 6.0	361013304010	361013304010

*Please note: Part Number 361013304110 for LK 600 only

Without nosepiece

SETTING TOOL EXT00L-040-1

Hydropneumatic Tool for Series SK / LK with Mandrel Collection Device

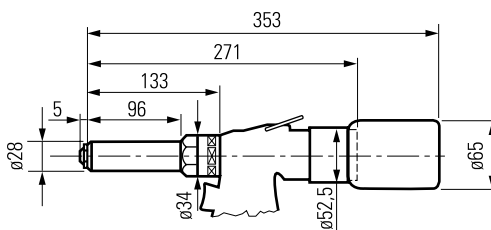

3D DATA: www.sfckoenig.com

Type	EXT00L-040-1	EXT00L-040-1
Serie	SK	LK
Order Number	300160393	300160393
Weight	2,7 kg	2,7 kg
Pull force at 7 bar	24 kN	24 kN
Working stroke	18 mm	18 mm
Air supply pressure (min.- max.)	5-7 bar	5-7 bar
Air consumption at 5-6 bar	3,5 l	3,5 l
Noise level	< 75 dB(A)	< 75 dB(A)
Cycle time	2.0 s	2.0 s
Nosepiece (not included) Expander Ø 7.0	361013307100	361013307100
Nosepiece (not included) Expander Ø 8.0	361013308100	361013308100
Nosepiece (not included) Expander Ø 9.0	361013309100	361013309100
Nosepiece (not included) Expander Ø 10.0	361013310100	361013310100
Jaws Expander Ø 7.0 - 10.0	361130400507-3-1	361130400507-3-1
Jaws case Expander Ø 7.0 - 10.0	361059120013	361059120013
Jaws pusher Expander Ø 7.0 - 10.0	361013307010	361013307010

Without nosepiece

SETTING TOOL EXT00L-040-2

Hydropneumatic Tool for Series LK and SK with Mandrel Collection Device

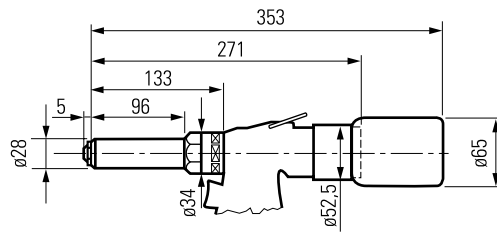

Technical data	EXT00L-040-2
Serie	LK / SK
Order Number	300161931
Weight	2,7 kg
Pull force at 7 bar	24 kN
Working stroke	18 mm
Air supply pressure (min.- max.)	5-7 bar
Air consumption at 5-6 bar	3,5 l
Noise level	< 75 dB(A)
Cycle time	2.0 s
Nosepiece (not included) Expander Ø 12.0	361013312100
Nosepiece (not included) Expander Ø 14.0	361013314100
Nosepiece (not included) Expander Ø 16.0	361013316100
Jaws Expander Ø 12.0 - 16.0	361130400512-3-1
Jaws case Expander Ø 12.0 - 16.0	361059120013
Jaws pusher Expander Ø 12.0 - 16.0	361013307010

Without nosepiece

SETTING TOOL KW-008

Mechanical Hand Lever Tool for Series SK / LK

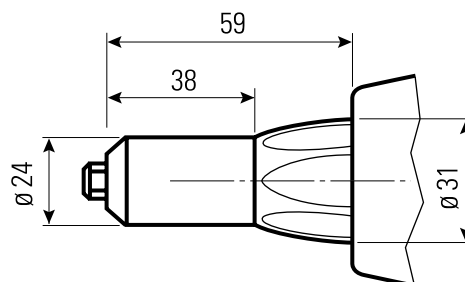

3D DATA: www.sfckoenig.com

Type	KW-008	KW-008
Serie	SK	LK
Order Number	300159301	300159301
Weight	1,95 kg	1,95 kg
Length	515 mm	515 mm
Nosepiece Expander \varnothing 3.0	-	-
Nosepiece Expander \varnothing 4.0	DPM400-C10	DPM400-B10
Nosepiece Expander \varnothing 5.0	DPM400-D10	DPM400-D10
Nosepiece Expander \varnothing 6.0	DPM400-E10	DPM400-E10
Jaws \varnothing 3.0 - 6.0	PRG 540-46E	PRG 540-46E

Hand lever tool with equipment for SK and LK \varnothing 4 - 6mm





Systems and Automation Solutions

At SFC KOENIG, a complete sealing and flow control solution means the right products are combined with the right assembly and installation processes. By helping customers integrate our parts into their operations we are able to improve efficiency, improve consistency and lower total costs. Our team is ready to work with you to develop a complete automation solution designed for your needs.



We support customers throughout the entire process – from planning, design and product selection, through to development and implementation. SFC KOENIG automation equipment, such as presses and hydraulic tools, combined with our process integration services, allows us to deliver a customized total solution for your operation.

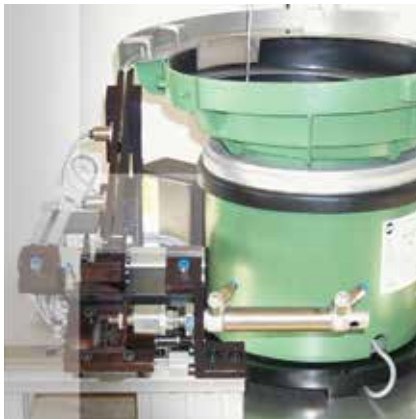

In conjunction with our automation partners, SFC KOENIG offers single-head workstations as well as fully-automated assembly equipment. The direction, type and number of assembly heads can all be customized and integrated into your production line. Built-in processing diagnostics control the assembly process for improved product quality.

SFC KOENIG automation solutions help to ensure that products are placed accurately and consistently, eliminating errors and potential risks. Our customized solutions are developed for efficiency and help you reduce assembly time and lower costs. Our high quality assembly systems:



- are efficient and reliable
- automatically feed sealing and flow control products
- easily integrate into assembly lines
- strictly control the installation process
- offer process flexibility
- improve product quality
- feature a modular design of the placing head
- are capable of high process speeds
- feature PLC control and monitoring
- increase throughput
- utilize a robust design



CHAPTER CONTENTS

84	Test Pressure	100 – 103	KOENIG CHECK VALVE®
85	Base Materials / Installation Requirements	104 – 105	KOENIG RESTRICTOR®
86 – 87	Pressure Performance	106	Hardness Conversion Table for Hardenable Carbon and Low Alloy Steel
88 – 89	Anchoring Principle	107 – 108	KOENIG EXPANDER® Systems / Product Comparison
90 – 94	Installation Instructions	109	Quality Assurance
95 – 97	Design Guidelines		
98 – 99	Galvanic Corrosion		

Full Line of Sealing & Flow Control Technologies

TECHNICAL INFORMATION

Information About CV Series Available Upon Request

KOENIG EXPANDER®

KOENIG CHECK VALVE®

KOENIG RESTRICTOR®

Our technical information section contains reference details related to performance, installation and materials. SFC KOENIG engineers are available to assist you at any time, and can advise on questions and concerns about your individual application. We also offer special orders for customized solutions to meet your individual needs.

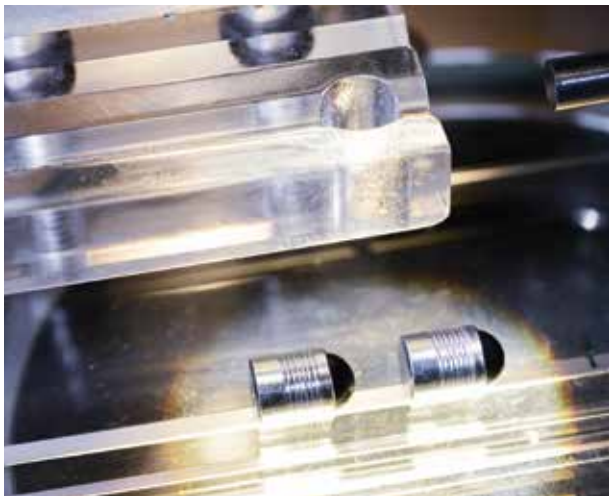

KOENIG EXPANDER® TEST PRESSURE

TEST PRESSURE[Ⓐ]

The KOENIG EXPANDER® is statically loaded up to burst pressure. This test is performed at SFC KOENIG for functional testing during the production process.

Samples from each production batch are subjected to this functional test.

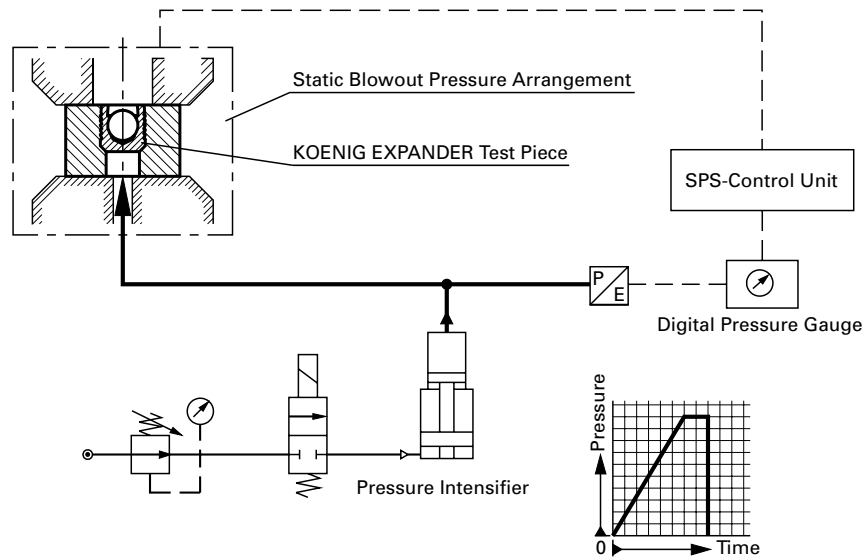

TEST PRESSURE, TEST[Ⓑ]

The KOENIG EXPANDER® is subjected to a pressure cycling test under varying environmental conditions. The test determines the levels of pressure that can be absorbed by the part by applying intermittent pressure loads and temperature fluctuations to confirm the sealing plug is not squeezed out.

CONDITIONS

- Temperature: 2 hrs at +100° C (Series LK/LP at 150° C) / 2 hrs at – 40° C temperature cycle 30 – 45 min.
- Pressure: Intermittent, 2 min 0 bar, 3 min test pressure
- Duration: 168 hrs (long-term test)
- Bore: Tolerance, roundness and roughness in accordance with standard sheets, plain surface, edge and wall distance according to standard sheet

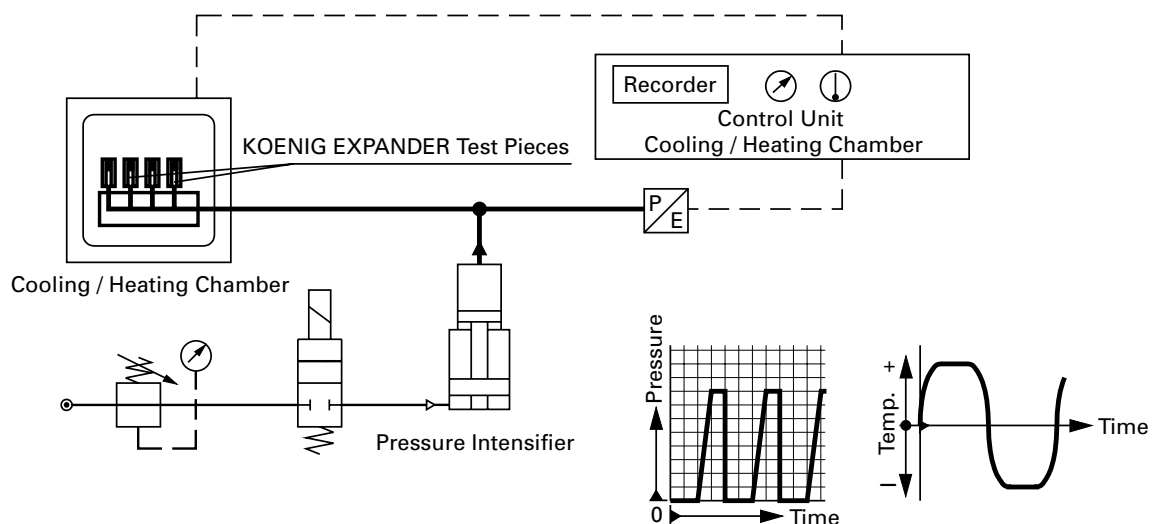

BASE MATERIALS / INSTALLATION REQUIREMENTS

The operating pressures listed can be achieved under the following conditions:

Base Material of the Installation		Tensile Strength (avg.) Rm [N/mm ²]	Elongation (min.) A5 [%]	Ultimate Strength (avg.) Rp0.2 [N/mm ²]	Hardness (min.) HB
①	High Strength Steel ETG-100 / 44SMn28 AISI 1144	1000	6	865	280
②	Case Harden Steel C15Pb 1.0403	560	10	300	180
③	Ductile Cast Iron EN-GJS-600-3 EN 1563	650	3	425	200
④	Gray Cast Iron EN-GJL-250 EN 1561	250	0.3	200	160
⑤	Aluminum-Alloy AlCu4Mg1 EN AW-2024-T3/AA-2024	480	8	380	120
⑥	Aluminum-Alloy AlMgSiPb EN AW-6012-T6/AA-6012-T6	340	8	300	80
⑦	Cast Aluminum-Alloy G-AlSi7Mg EN AC-42100/A356	300	4	250	80

- Equally high working pressures can also be achieved with base materials with similar mechanical properties. However, compliance must be met for the appropriate installation conditions.
- Applications in cast aluminum, magnesium alloys, nonferrous metals and plastics require special consideration and can be developed upon request.
- Applications in base materials with high hardness and hardened materials, require special consideration and can be developed upon request.
- **Applications in surface coated materials (zinc plated, anodized ...) require special consideration and can be developed upon request.**
- For factors affecting operating pressures please see:
 - Anchoring Principle
 - Surface Finish: Requirements
 - Design Guidelines

SAFETY MARGIN

The safety margin includes uncontrollable factors. Dynamic loads at nominal pressure, with 10⁶ load cycles and a frequency of 3 – 4 Hz have shown that the subsequently measured bursting pressures, are reduced according to Test Ⓐ by 20 % as well as Test Ⓑ.

PRESSURE PERFORMANCE

Series MB

Series MB 600 mm	Base Material of the Installation						
	① ETG-100 / 44SMn28 AISI 1144	② C15Pb 1.0403	③ EN-GJS-600-3 EN 1563	④ EN-GJL-250 EN 1561	⑤ AlCu4Mg1 EN AW-2024-T3	⑥ AlMgSiPb EN AW-6012-T6	⑦ G-AlSi7Mg EN AC-42100
Ø 3 – 10	1400 bar / 20300 psi 450 bar / 6500 psi					1200 bar / 17400 psi 380 bar / 5500 psi	
Ø 12 – 14	1000 bar / 14500 psi 350 bar / 5100 psi					900 bar / 13000 psi 280 bar / 4100 psi	
Hole Tolerance	0/+0,1 mm						
Hole Roughness	R _z 10 – 30 µm			Anchorage in Base Metal			

Series MB 600 Inch	Base Material of the Installation						
	① ETG-100 / 44SMn28 AISI 1144	② C15Pb 1.0403	③ EN-GJS-600-3 EN 1563	④ EN-GJL-250 EN 1561	⑤ AlCu4Mg1 EN AW-2024-T3	⑥ AlMgSiPb EN AW-6012-T6	⑦ G-AlSi7Mg EN AC-42100
Ø 0.093 – 0.281	1400 bar / 20300 psi 450 bar / 6500 psi					1200 bar / 17400 psi 380 bar / 5500 psi	
Hole Tolerance	Ø 0,093 0/+0,002 Inch from Ø 0,125 0/+0,004 Inch						
Hole Roughness	R _z 10 – 30 µm			Anchorage in Base Metal			

Series MB 700 mm	Base Material of the Installation						
	① ETG-100 / 44SMn28 AISI 1144	② C15Pb 1.0403	③ EN-GJS-600-3 EN 1563	④ EN-GJL-250 EN 1561	⑤ AlCu4Mg1 EN AW-2024-T3	⑥ AlMgSiPb EN AW-6012-T6	⑦ G-AlSi7Mg EN AC-42100
Ø 3 – 10	1400 bar / 20300 psi 450 bar / 6500 psi					1200 bar / 17400 psi 380 bar / 5500 psi	
Ø 12 – 22	1150 bar / 16700 psi 350 bar / 5100 psi					900 bar / 13000 psi 280 bar / 4100 psi	
Hole Tolerance	0/+0,1 mm						
Hole Roughness	R _z 10 – 30 µm			Anchorage in Base Metal			

Series MB 850 mm	Base Material of the Installation						
	① ETG-100 / 44SMn28 AISI 1144	② C15Pb 1.0403	③ EN-GJS-600-3 EN 1563	④ EN-GJL-250 EN 1561	⑤ AlCu4Mg1 EN AW-2024-T3	⑥ AlMgSiPb EN AW-6012-T6	⑦ G-AlSi7Mg EN AC-42100
Ø 3 – 10	1100 bar / 16000 psi 350 bar / 5100 psi					1000 bar / 14500 psi 320 bar / 4600 psi	
Ø 12 – 22	900 bar / 13000 psi 280 bar / 4100 psi					800 bar / 11600 psi 250 bar / 3600 psi	
Hole Tolerance	0/+0,1 mm						
Hole Roughness	R _z 10 – 30 µm			Anchorage in Base Metal			

Proof Pressure Test®

Max. Allowable Working Pressure = Nominal Pressure

Hard Base Material: To achieve the allowable working pressure, anchorage to the bore roughness of the base material is required. Roughness R_z = 10 – 30 µm.

Soft Base Material: Anchorage to the bore of the base material occurs automatically due to the serrations on the sleeve of the KOENIG EXPANDER®.

Transition Zone: To achieve the allowable working pressure, anchorage to the bore roughness of the base material is required. Roughness R_z = 10 to 30 µm.

See Anchorage Principles related to the base materials on page 88.

PRESSURE PERFORMANCE

Series SK / LP / LK

Series SK mm	Base Material of the Installation						
	①	②	③	④	⑤	⑥	⑦
	ETG-100 / 44SMn28 AISI 1144	C15Pb 1.0403	EN-GJS-600-3 EN 1563	EN-GJL-250 EN 1561	AlCu4Mg1 EN AW-2024-T3	AlMgSiPb EN AW-6012-T6	G-AISI7Mg EN AC-42100
ø 4 – 10	1600 bar / 23200 psi 500 bar / 7200 psi				1400 bar / 20300 psi 450 bar / 6500 psi		
ø 12	1600 bar / 23200 psi 400 bar / 5800 psi						
Hole Tolerance	0/+0,12 mm						
Hole Roughness	R _z 10 – 30 µm				Anchorage in Base Metal		

If SK plugs are used to keep channels separated, allowable working pressure on the insertion side is reduced by 50%.

Series LP mm	Base Material of the Installation						
	①	②	③	④	⑤	⑥	⑦
	ETG-100 / 44SMn28 AISI 1144	C15Pb 1.0403	EN-GJS-600-3 EN 1563	EN-GJL-250 EN 1561	AlCu4Mg1 EN AW-2024-T3	AlMgSiPb EN AW-6012-T6	G-AISI7Mg EN AC-42100
ø 4 – 12	180 bar / 2600 psi				60 bar / 850 psi		
Hole Tolerance	According to Data Sheet						
Hole Roughness	R _z 10 – 30 µm				Anchorage in Base Metal		

① ② ③ ④ ⑤ Temperature range for proof pressure testⓈ: – 40 °C to + 150 °C ⑥ ⑦ Temperature range for proof pressure testⓈ: – 40 °C to + 100 °C

Series LK 600 mm	Base Material of the Installation						
	①	②	③	④	⑤	⑥	⑦
	ETG-100 / 44SMn28 AISI 1144	C15Pb 1.0403	EN-GJS-600-3 EN 1563	EN-GJL-250 EN 1561	AlCu4Mg1 EN AW-2024-T3	AlMgSiPb EN AW-6012-T6	G-AISI7Mg EN AC-42100
ø 4 – 10	180 bar / 2600 psi				60 bar / 850 psi		
Hole Tolerance	0/+0,12 mm						
Hole Roughness	R _z 10 – 30 µm				Anchorage in Base Metal		

① ② ③ ④ Temperature range for proof pressure testⓈ: – 40 °C to + 150 °C ⑤ ⑥ ⑦ Temperature range for proof pressure testⓈ: – 40 °C to + 100 °C

Series LK 950 mm	Base Material of the Installation						
	①	②	③	④	⑤	⑥	⑦
	ETG-100 / 44SMn28 AISI 1144	C15Pb 1.0403	EN-GJS-600-3 EN 1563	EN-GJL-250 EN 1561	AlCu4Mg1 EN AW-2024-T3	AlMgSiPb EN AW-6012-T6	G-AISI7Mg EN AC-42100
ø 4 – 18	180 bar / 2600 psi				60 bar / 850 psi		
Hole Tolerance	0/+0,12 mm						
Hole Roughness	R _z 10 – 30 µm				Partial Anchorage in Base Metal		Anchorage in Base Metal

① ② ③ ④ Temperature range for proof pressure testⓈ: – 40 °C to + 150 °C ⑤ ⑥ ⑦ Temperature range for proof pressure testⓈ: – 40 °C to + 100 °C

KOENIG EXPANDER® sealing plugs series LK are not suitable for pressure load applied on the insertion side of the plug. For special release contact SFC KOENIG.

Proof Pressure Test Ⓢ

Max. Allowable Working Pressure = Nominal Pressure

Hard Base Material: To achieve the allowable working pressure, anchorage to the bore roughness of the base material is required.
Roughness R_z = 10 – 30 µm.

Soft Base Material: Anchorage to the bore of the base material occurs automatically due to the serrations on the sleeve of the KOENIG EXPANDER®.

Transition Zone: To achieve the allowable working pressure, anchorage to the bore roughness of the base material is required.
Roughness R_z = 10 to 30 µm.

See Anchorage Principles related to the base materials on page 88.

ANCHORAGE PRINCIPLE

The required bore roughness is directly related to the hardness and the mechanical characteristics of the base material. Depending on the combination of sealing plug and base material, anchorage takes place either by the groove profile of the expander sleeve biting into the base material or on anchorage to the surface roughness of the bore.

Note:

When selecting a KOENIG EXPANDER® the bore roughness must always be adjusted according to the hardness of the base material.

Anchorage between sleeve and base material is achieved when the sleeve is a minimum of HB = 30 greater than the base material. If the hardness difference is less, hole roughness of 10 to 30 µm is needed to achieve indicated working pressures.

Anchorage Principle Related to the Base Material

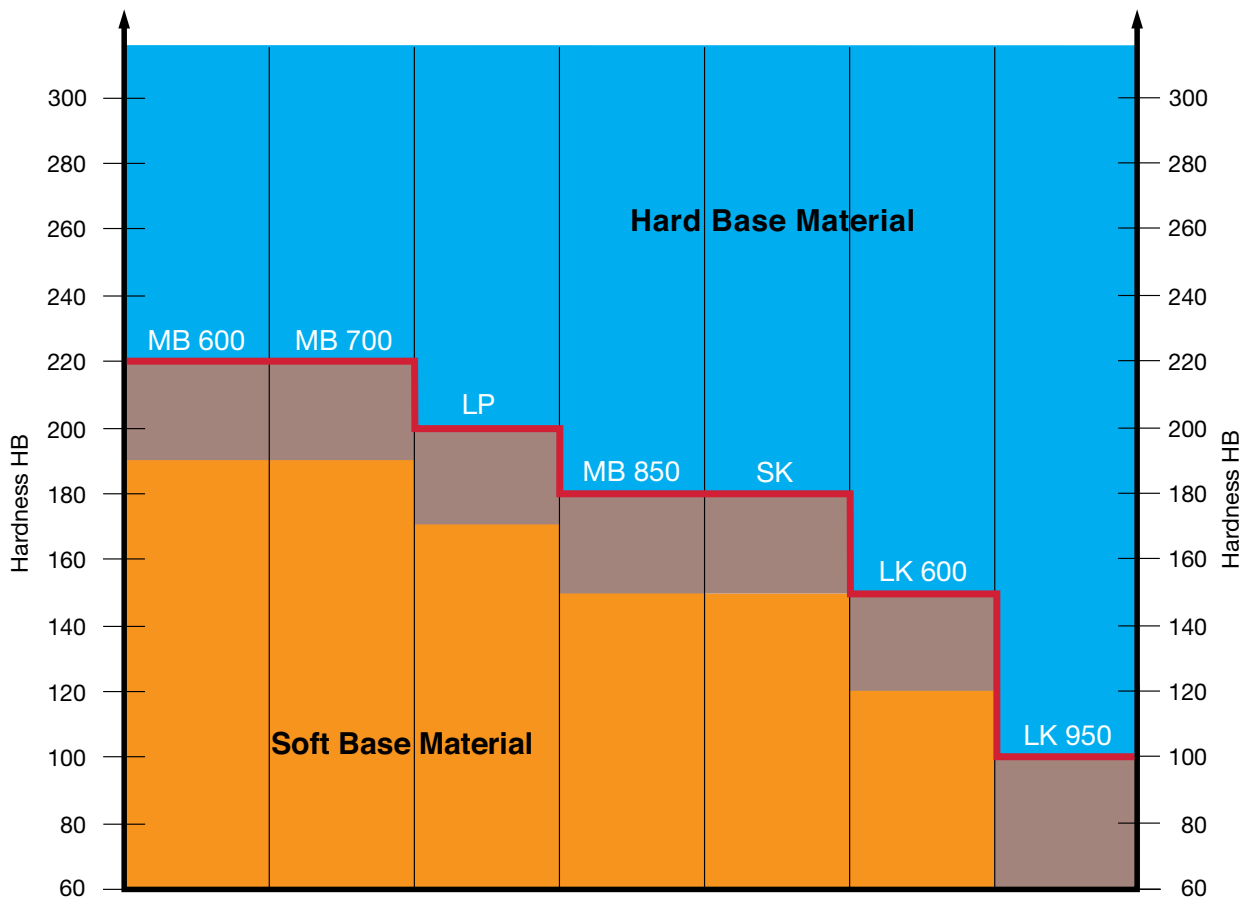

KOENIG EXPANDER®

Hard Base Material: To achieve the allowable working pressure, anchorage to the bore roughness of the base material is required.
Roughness $R_z = 10 - 30 \mu\text{m}$.

Transition Zone: To achieve the allowable working pressure, anchorage to the bore roughness of the base material is required.
Roughness $R_z = 10 \text{ to } 30 \mu\text{m}$.

Soft Base Material: Anchorage to the bore of the base material occurs automatically due to the serrations on the sleeve of the KOENIG EXPANDER®.

ANCHORAGE PRINCIPLE



Anchorage due to plug sleeve serrations
KOENIG EXPANDER® Series SK
 In aluminum-alloy HB = 90



Anchorage due to plug sleeve serrations
KOENIG EXPANDER® Series MB 850
 In aluminum-alloy HB = 90

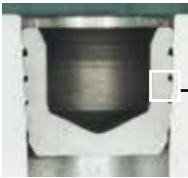

Anchorage due to plug sleeve serrations
KOENIG EXPANDER® Series LP
 In aluminum-alloy HB = 90



Sufficient anchorage due to plug sleeve serrations
KOENIG EXPANDER® Series LK 950
 In aluminum-alloy HB = 90

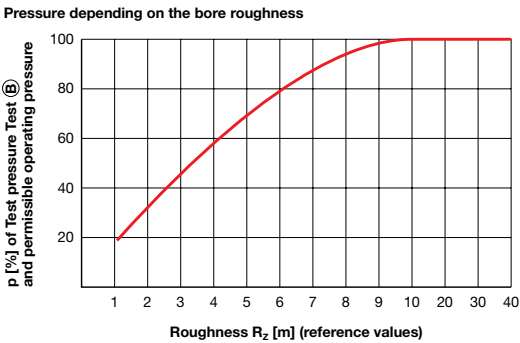

BORE ROUGHNESS REQUIREMENTS

When installing KOENIG EXPANDER® plugs in hard base material positive anchoring is not possible. To attain suitable working pressures and anchorage, it is necessary to have a bore roughness of $R_z = 10-30 \mu\text{m}$. At a roughness greater than $R_z = 30 \mu\text{m}$ leakage might occur.

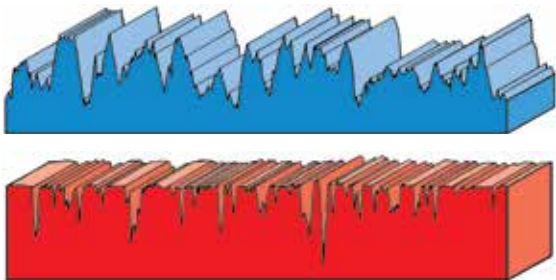

ROUGHNESS PROFILE

Required Roughness Profile

The ideal bore roughness for anchorage is attained by drilling with a twist drill or a core drill.

Undesirable Roughness Profile

By reaming, a one-sided, smooth roughness profile is created. This is not desirable.

INSTALLATION INSTRUCTIONS FOR SERIES MB

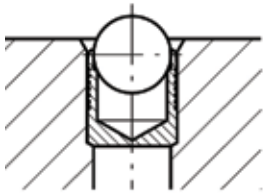

Fig. 1

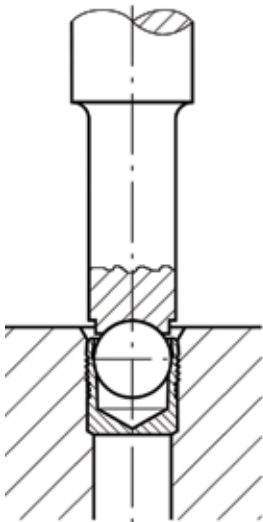

Fig. 2

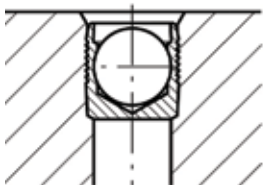

Fig. 3

DRILLED HOLE

- The drilled hole must be within the tolerances shown on the preceding dimensional sheets.
- The counterbored hole (d_2) must be properly sized for the through hole (d_3) according to the dimensional sheets.
- Holes must be round within 0.05 mm.
- With hard materials the bore roughness should be from $R_z = 10-30 \mu\text{m}$ for best results.
- Longitudinal rifles and spiral grooves should be avoided. These influence the sealing effectiveness.
- The bore must be free of oil, grease and chips.

SETTING PROCEDURE

- With the ball facing out the KOENIG EXPANDER® is inserted in the counterbored hole. The top sleeve should not be above the surface of the base material (Fig. 1).
- With only a slight or no counterbore, the base of the sleeve must be adequately supported during installation.
- The ball can now be pressed in until the top of the ball is below the edge of the sleeve (Fig. 2 and 3). Corresponding approximate values for stroke S as well as the dimensions X are from the table below.

Note:

- Use the proper size setting tool for the KOENIG EXPANDER® according to the data sheet.
- Spray cleaning with air drying is the only way to clean/degrease plugs before installation. Do not dip and vacuum dry the plugs.

PRESS

Small quantities or single parts can be installed with a hammer and a setting tool. Installation can also be done with an arbor press. It is preferred to limit stroke travel when using a press because insertion force is difficult to control. KOENIG EXPANDER® plugs are also ideal for automated installation because they are problem free.

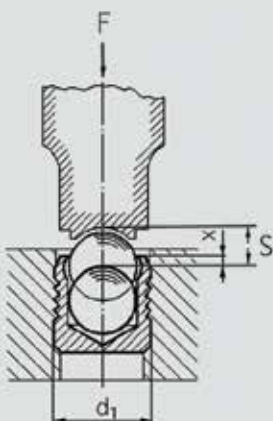

INSTALLATION CHART

		Series MB 600 / MB 700 / MB 850													
d1 [mm]		3	4	5	6	7	8	9	10	12	14	16	18	20	22
S [mm]	Stroke (approx. values)	1,2	1,5	2,0	2,5	3,0	3,5	4,0	4,5	5,5	6,35	7,0	8,0	9,0	10,0
X [mm]	Position of Top of Ball Relative to Top of Sleeve $\pm 0,2$	0,4	0,2	0,4	0,4	0,4	0,3	0,4	0,4	0,4	0,4	0,6	0,6	0,8	0,8

		Series MB 600 Inch-Version						
d1 [inch]		.093	.125	.156	.187	.218	.250	.281
S [in]	Stroke (approx. values)	.031	.047	.059	.079	.094	.109	.118
X [in]	Position of Top of Ball Relative to Top of Sleeve	Flush to .012 Below the Sleeve						

INSTALLATION INSTRUCTIONS FOR SERIES MB

PLUG REMOVAL

With KOENIG EXPANDER® MB Series removal of the plug is possible. The plug can be drilled out with a carbide tipped drill or with a high speed steel drill.

Plug Removal Drill Bit Recommendation		
MB 600-030 to 140	Ball HB ~200	High Speed Steel Drill
MB 600-093 A	Ball HRC ~55	Carbide Tipped Drill
MB 600-125 A to 281 A	Ball HB ~200	High Speed Steel Drill
MB 700-030 to 220	Ball HRC ~45	Carbide Tipped Drill
MB 850-030 to 220	Ball HRC ~45	Carbide Tipped Drill

PROCEDURE:

- For KOENIG EXPANDER® smaller than 6mm or .250 inches in diameter:
Drill out, in one process, to the **next larger diameter** according to the data sheet.
- For KOENIG EXPANDER® models larger than 6mm or .250 inches in diameter:
Drill out in several steps with last step to the **next larger diameter** according to the data sheet.
- Clear chips, remnants of the sleeve, and oil and grease from the bore.
- Inspect bore to confirm that it meets all requirements.
- Install a new KOENIG EXPANDER®.

Note:

After plug removal always use the next larger size plug.

INSTALLATION INSTRUCTIONS FOR SERIES SK

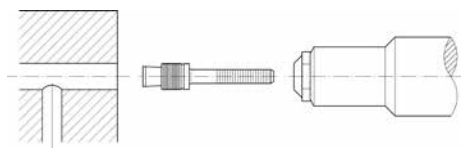

Fig. 1

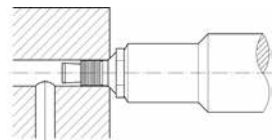

Fig. 2

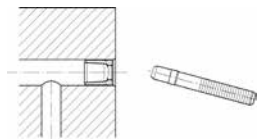

Fig. 3

DRILLED HOLE

- The drilled hole must be within the tolerances shown on the preceding data sheets.
- Holes must be round within 0.05 mm.
- With hard materials the bore roughness should be from $R_z = 10\text{--}30\ \mu\text{m}$ for best results.
- Longitudinal rifles and spiral grooves should be avoided. These influence the sealing effectiveness.
- The bore must be free of oil, grease and chips.

SETTING PROCEDURE

- Insert the plug in the tool, making sure that the sleeve is against the nosepiece (Fig. 1).
- After inserting the plug into the hole (ensuring the tool is flush to the work surface) activate the tool to expand the plug. The mandrel will break apart when the proper tension has been reached (Fig. 2 and 3).

Note:

- The assembly of KOENIG EXPANDER® plugs should only be done in a **clean working area**.
- The sleeve and mandrel of the **plug should not be cleaned, lubricated or have sealant (compound) applied**.

TOOLS

For trouble free installation of KOENIG EXPANDER® plugs use the tools and appropriate components according to the data sheet.

PLUG REMOVAL

With KOENIG EXPANDER® SK Series plug removal is possible.

PROCEDURE:

- Drive the mandrel from the sleeve with a punch.
- Drill out the sleeve and remove the mandrel.
- Bore the hole to the **next larger Expander diameter** per the data sheet.
- Clear chips, remnants of the sleeve, and oil and grease from the bore.
- Inspect bore to confirm that it meets all requirements.
- Install a new KOENIG EXPANDER®.

Note:

After plug removal always install the next larger size plug.

INSTALLATION INSTRUCTIONS FOR SERIES LK

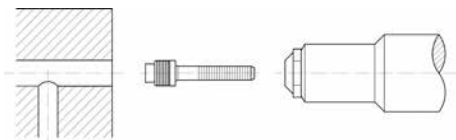

Fig. 1

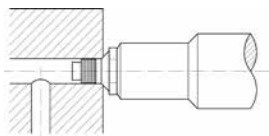

Fig. 2

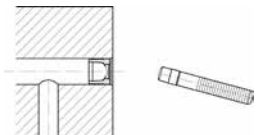

Fig. 3

DRILLED HOLE

1. The drilled hole must be within the tolerance shown on the dimensional sheets. In base materials with high hardness or hardened materials:
 - < 280HB the bore tolerance should be $0 / + 0.12$
 - $\geq 280HB$ the bore tolerance should be $+0.05 / + 0.15$
2. Holes must be round within 0.05 mm.
3. With hard materials the bore roughness should be from $R_z = 10-30 \mu\text{m}$ for best results.
4. Longitudinal rifles and spiral grooves should be avoided. These influence the sealing effectiveness.
5. The bore must be free of oil, grease and chips.

SETTING PROCEDURE

- Insert the plug in the tool, ensuring that the sleeve is against the nosepiece (Fig. 1).
- After inserting the plug into the hole activate the tool to expand the plug.
- The mandrel will break apart when the proper tension has been reached (Fig. 2 and 3).

Note:

- The assembly of KOENIG EXPANDER® plugs should only be done in a **clean working area**.
- The sleeve and mandrel of **the plug should not be cleaned, lubricated or have sealant (compound) applied**.

TOOLS

For trouble free installation of KOENIG EXPANDER® plugs use the tools and appropriate components according to the data sheet.

PLUG REMOVAL

With KOENIG EXPANDER® plugs LK Series plug removal is possible.

PROCEDURE:

- Drive the mandrel from the sleeve with a punch.
- Drill out the sleeve and remove the mandrel.
- Bore the hole to the **next larger Expander diameter** per the data sheet.
- Clear chips, remnants of the sleeve and oil and grease from the bore.
- Inspect bore to confirm that it meets all requirements.
- Install a new KOENIG EXPANDER®.

Note:

After plug removal always install the next larger size plug.

INSTALLATION INSTRUCTIONS FOR SERIES LP

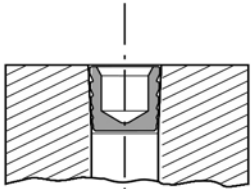

Fig. 1

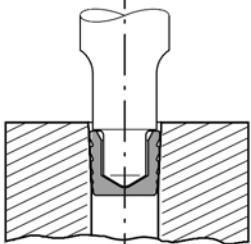

Fig. 2

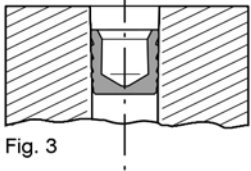

Fig. 3

DRILLED HOLE

- The drilled hole must be within the tolerances shown on the dimensional sheets.
- A 1:12 cone rate must be maintained as per the specification sheet.
- Holes must be round within 0.05 mm.
- With hard materials the bore roughness should be from $R_z = 10-30 \mu\text{m}$ for best results.
- Longitudinal rifles and spiral grooves should be avoided. These influence the sealing effectiveness.
- The bore must be free of oil, grease and chips.

SETTING PROCEDURE

- With the setting hole facing out, the LP-plug is inserted in the cone bore. The top sleeve should not be above the surface of the base material (Fig. 1).
- The LP-plug can now be pressed in with the setting tool. Corresponding approximate values for stroke S are from the table below (Fig. 2).
- Installed LP-plug (Fig. 3).

Note:

- Use the proper size setting tool for the KOENIG EXPANDER® according to the data sheet.
- A higher setting force might occur if the LP plugs are washed before installation.

PRESS

- It is preferred to limit travel when using a press because insertion force is difficult to control.
- Recommended setting speed is 5 mm/sec.
- The KOENIG EXPANDER® ensures an optimum orientation, it works perfectly with automatic processing.

PLUG REMOVAL

With KOENIG EXPANDER® LP Series plug removal is possible. The plug can be drilled out with a high speed steel drill.

PROCEDURE:

- Drill out, in one process, to the next larger diameter, nominal diameter d4 according to the data sheet.
- Drill the taper hole with a reamer up to diameter d3 according to the data sheet.
- Clear chips, remnants of the sleeve, and oil and grease from the bore.
- Install a new KOENIG EXPANDER®.

Note:

After plug removal always install the next larger size plug.

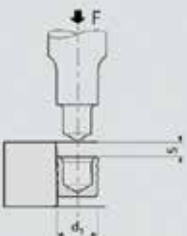

INSTALLATION CHART

		Series LP 900							
	X (mm)	4	5	6	7	8	9	10	12
S (mm)	Stroke	1,0	1,3	1,3	1,5	1,8	1,8	2,0	2,0
	±0,25								
	(average value)								

In steel, gray cast nodulized cast iron, aluminum wrought alloy, aluminum-cast material

DESIGN GUIDELINES

Distance to External Wall

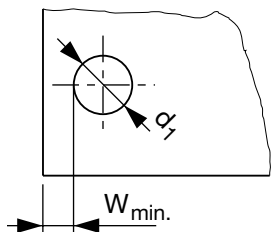

Distance to Exterior Wall

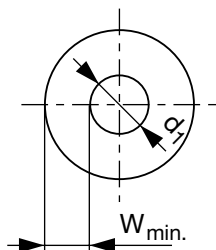

Wall Thickness Between Bores

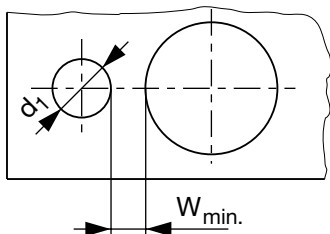

WALL THICKNESS / DISTANCE FROM EDGE

As the radial expansion of the KOENIG EXPANDER® sleeve occurs, the base material in which it will be anchored plastically deforms. The resultant strength, as well as the hydraulic pressure and temperature service conditions depending on the expander type and characteristics of the base material, require minimum wall thickness, or distance from edge.

The guideline values for minimum wall thickness and distance from edge ($W_{min.}$) express these influencing factors. At these minimum values, only slight deformation on the exterior profile of the base material of less than 20 μm is likely. This does not affect the function of the KOENIG EXPANDER®. Below the guideline values ($W_{min.}$) the possibility of overloading the base material exists, which can adversely influence the function of the KOENIG EXPANDER®. In such cases tests must be conducted.

Guideline values $W_{min.}$ for wall thickness and distance from edge

KOENIG EXPANDER® diameters Series MB / SK and LP

$$d_1 \geq 4 \text{ mm: } W_{min.} = f_{min.} \times d_1$$

$$d_1 < 4 \text{ mm: } W_{min.} = f_{min.} \times d_1 + 0,5 \text{ mm}$$

KOENIG EXPANDER® diameters Series LK

$$d_1 \geq 5 \text{ mm: } W_{min.} = f_{min.} \times d_1$$

$$d_1 = 4 \text{ mm: } W_{min.} = f_{min.} \times d_1 + 0,5 \text{ mm}$$

		①	②	③	④	⑤	⑥	⑦
Base Material	Description	ETG100	C15Pb	EN-GJS-600-3	EN-GJL-250	AlCu4Mg1	AlMgSiPb	G-AlSi7Mg
	Avg. Tensile Strength R_m [N/mm ²]	1000	560	650	250	480	340	300
	Minimum Elongation A5 [%]	6	10	3	0.3	8	8	4
	Avg. Ultimate Strength $R_{p0,2}$ [N/mm ²]	865	300	425	200	380	300	250
KOENIG EXPANDER® Series		Factor f_{min}						
MB 600		0,6	0,8	1,0	0,8	0,8	1,0	1,0
MB 600, Inch-Version		0,6	0,8	1,0	0,8	0,8	1,0	1,0
MB 700		0,6	0,8	1,0	0,8	0,8	1,0	1,0
MB 850		0,5	0,6	1,0	0,6	0,6	1,0	1,0
SK		0,5	0,6	1,0	0,6	0,6	1,0	1,0
LP		0,3	0,3	0,5	0,3	0,4	0,5	0,5
LK 600		0,4	0,5	0,8	0,5	0,7	0,7	0,7
LK 950		0,3	0,3	0,6	0,5	0,4	0,5	0,5

DESIGN GUIDELINES

Required Installation Lengths

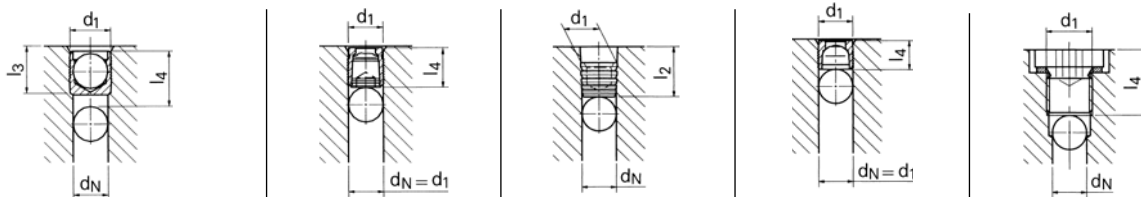

d_N	Series MB			Series SK		Series LP		Series LK		Threaded Plugs DIN 908	
	d_1	l_3 min.	l_4 min.	d_1	l_4 max.	d_1	l_2 min.	d_1	l_4 max.	d_1	l_4 max.
2,0	3,0	3,4	5,0								
3,0	4,0	3,8	5,5								
4,0	5,0	5,3	7,0	4,0	6,5	4,40	7,0	4,0	4,0		
5,0	6,0	6,3	8,5	5,0	7,5	5,40	8,0	5,0	4,8	M8x1,5	11,5
6,0	7,0	7,3	9,5	6,0	8,0	6,40	8,5	6,0	5,3	M8x1,5	11,5
7,0	8,0	8,3	11,0	7,0	9,0	7,40	8,5	7,0	5,8	M10x1,5	12,0
8,0	9,0	9,8	12,5	8,0	10,5	8,45	9,5	8,0	6,8	M10x1,5	12,0
9,0	10,0	10,8	13,5	9,0	11,0	9,60	10,0	9,0	6,8	M12x1,5	16,0
10,0	12,0	12,8	16,0	10,0	12,5	10,65	11,0	10,0	6,8	M12x1,5	16,0
12,0	14,0	14,5	18,0			12,75	12,0	12,0	7,8	M14x1,5	16,0
14,0	16,0	16,5	20,0					14,0	8,7	M16x1,5	16,5
16,0	18,0	18,5	22,5					16,0	11,5	M18x1,5	17,5
18,0	20,0	21,5	25,5					18,0	13,0	M20x1,5	19,5
20,0	22,0	24,5	28,5							M22x1,5	19,5

d_N = Given nominal bore / system bore size

*Installation Lengths Series MB

The required installation length (l_4) min. for MB plugs is for base materials with hardness greater than HB = 90.

For softer materials, deeper installation is required.

ROUNDNESS TOLERANCE

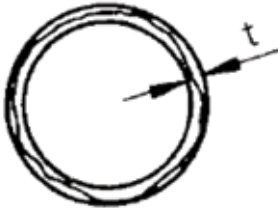

To ensure reliable functioning of the KOENIG EXPANDER® with regard to pressure performance and to ensure leak tight sealing, a **roundness tolerance of $t = 0.05 \text{ mm}$** must be held.

By using a double lipped twist drill, the called out hole and roundness tolerances are reached. Better tolerances, particularly for larger diameter holes, can be held by using a **triple lipped twist drill**.

CONICITY OF THE BORE

Within the effective sealing area of the KOENIG EXPANDER, the bore must be according to the dimensional sheets. The bore lead in can be chamfered up to a depth of **$0.25 \times d_1$ (LK: $0.15 \times d_1$)** because this area has no significant effect on the sealing function.

Series MB

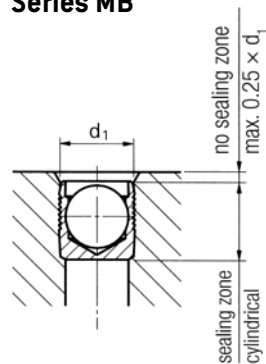

Series SK

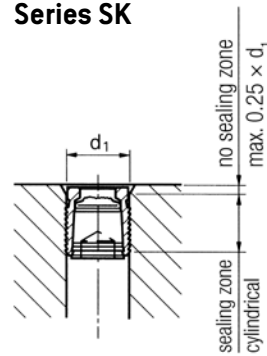

Series LP

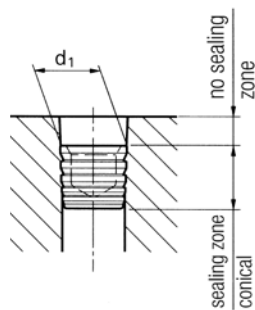

Series LK

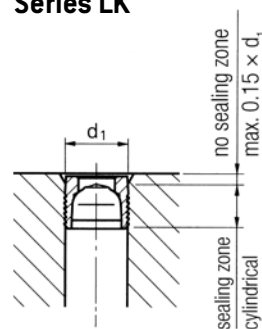

GALVANIC CORROSION

In choosing a KOENIG EXPANDER® you must consider that the material of the sealing plug and the material of the production piece can show different electrical potentials. In the presence of an electrolyte (e.g. 5% water-NaCl solution), this potential difference causes electrochemical attack on the least noble of the metals in contact – galvanic corrosion. In this case, either the base material or its surface protection will become the anode and will be transferred to the pure metal of the cathode. The corrosion speed or the current density will be determined by the relative surface area or volume of the anode and cathode as illustrated below.

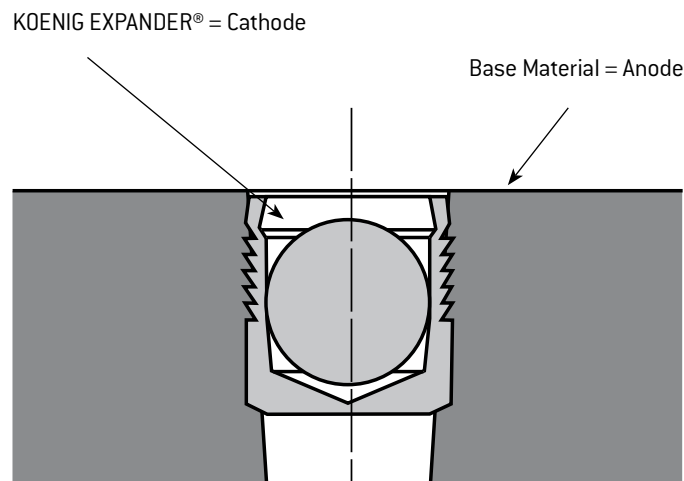
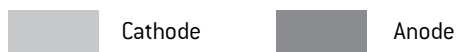

Large Anode Area —> Low Current Density at the Anode
—> **Slow Corrosion**

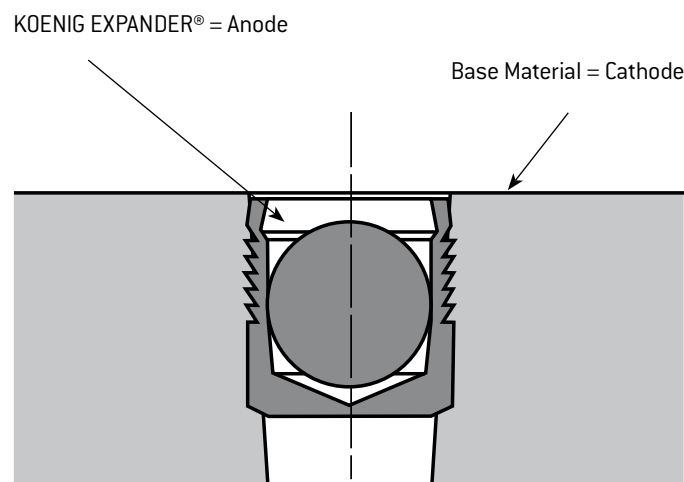

Small Anode Area —> High Current Density at the Anode
—> **Fast Corrosion**

GALVANIC CORROSION

EFFECT OF GALVANIC CORROSION

The following table shows the expected galvanic corrosion behavior of KOENIG EXPANDER® plugs in common base materials allowing for the relative surface areas of both metals, which influences the speed of corrosion.

Installation Material	Series													
	MB 600	MB 700	MB 850	CV 531	CV 533	CV 588	CV 851	SK	LP	LK 600	LK 950	BF/BR	RE/RT	
Steel, Carbon/Low Alloy, Plain														
Steel, Carbon/Low, Zn Plated, Chromate														
Steel, Carbon/Low Alloy, Phosphatized														
Nitrided or Case Hardened Steel	Behavior Depends on the Method Used													
Stainless Steel, X8CrNiS18-9, 1.4305, ANSI 303														
Stainless Steel, X12CrS13, 1.4005, ANSI 416														
Cast Iron, EN 1561, Plain														
Cast Iron, EN 1561, Zn Plated, Chromate														
Cast Iron, EN 1561, Phosphatized														
Ductile Cast Iron, EN 1563, Plain														
Ductile Cast Iron, EN 1561, Zn Plated, Chromate														
Ductile Cast Iron, EN 1561, Phosphatized														
AlMg1SiCu EN AW-6061														
AlMgSiPb EN AW-6062														
AlCu4Mg1 EN AW-2024														
AlZnMgCu1,5 EN AW-7075														
G-AlSi7Mg A-Norm 356														
G-AlSi9Mg														
G-AlSi10Mg														

 = Accelerated  + Not Accelerated  = Slightly Accelerated

Key to the galvanic corrosion behavior of KOENIG EXPANDER® plugs in the presence of an electrolytic medium installed in base materials per the above table.

Suggestions to Prevent Galvanic Corrosion

- Choose materials with no or low potential difference.
- Use corrosion reducing designs, i.e. if possible prevent the accumulation of fluids on the outer surface of the workpiece.
- By using suitable surface coatings, corrosion attack can be considerably reduced.

Salt spray testing per DIN EN ISO 9227 is available upon request

INSTALLATION INSTRUCTIONS FOR KOENIG CHECK VALVE®

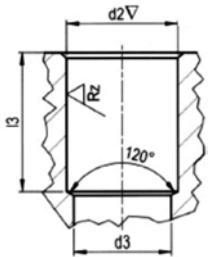

Fig. 1

Before Installation

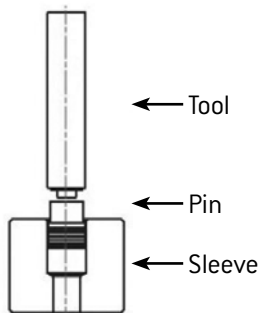

Fig. 2

After Installation

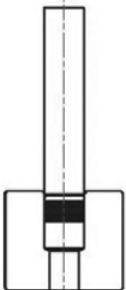

Fig. 3

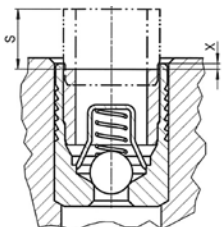

Fig. 4 (Reverse Flow)

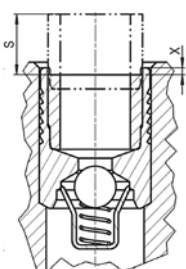

Fig. 5 (Forward Flow)

DRILLED HOLE

- The drilled hole (Fig. 1) must be within the tolerances shown on the preceding dimensional sheets.
- The counter-bored hole (d2) must be properly sized for the through hole (d3) according to the dimensional sheets.
- Hole must be round within 0.05 mm.
- With hard materials (HB > 190) the bore roughness should be from Rz = 10 – 30 µm for best results.
- Longitudinal rifles and spiral grooves should be avoided.
- The bore must be free of oil, grease and chips.
- Additional reaming operation on the hole is not required.

SETTING PROCEDURE

- With the pin facing out, the KOENIG CHECK VALVE® is inserted in the counter-bored hole (Fig. 2). The top surface of the sleeve should not be above the top surface of the base material.
- With only a slight or no counter-bore, the base of the sleeve must be adequately supported during installation.
- The pin can now be pressed in until the top of the pin is flush or within 0.3 mm with the top surface of the sleeve. Corresponding approximate values for stroke S, as well as the dimension X can be referred from the dimensional sheets (Fig. 3, 4 and 5).

Note

- Use the proper size setting tool for the KOENIG CHECK VALVE® according to the data sheet.
- Clean/degrease the KOENIG CHECK VALVE® before installation; only spray cleaning with air drying is allowed (no dipping or vacuum drying).
- Sealants or locking compounds should not be applied on the KOENIG CHECK VALVE®.

PRESS

Small quantities or single parts can be installed with a hammer and setting tool. Installation can also be done with an arbor press. It is preferred to limit stroke travel when using a press because insertion force is difficult to control. The KOENIG CHECK VALVE® is also ideal for automated installation.

ANCHORAGE PRINCIPLES FOR KOENIG CHECK VALVE®

The required bore roughness is directly related to the hardness and the mechanical characteristics of the base material. Depending on the combination of the KOENIG CHECK VALVE® and the base material, anchorage takes place either by the groove profile of the KOENIG CHECK VALVE® sleeve biting into the base material or on anchorage to the surface roughness of the bore.

Note:

When selecting a KOENIG CHECK VALVE®, the bore roughness must always be adjusted according to the hardness of the base material. Anchorage between sleeve and base material is achieved when the sleeve is a minimum of HB = 30 greater than the base material. If the hardness difference is less, hole roughness of 10 to 30 µm is needed to achieve good anchorage for the rated working pressure differential values.

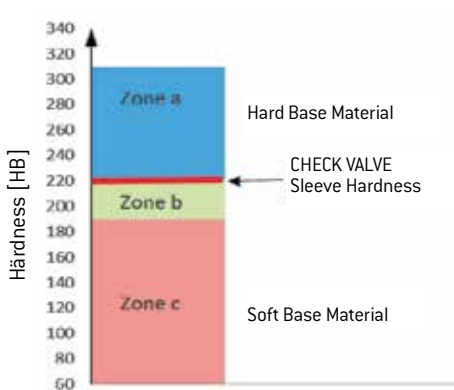

- Zone a – Hard Base Material (HB > 220)
To achieve the allowable working pressure, anchorage to the bore roughness of the base material is required.
Roughness $R_z = 10 - 30 \mu\text{m}$.
- Zone b – Transition Zone (HB 190 - 220)
To achieve the allowable working pressure, anchorage to the bore roughness of the base material is required.
Roughness $R_z = 10 - 30 \mu\text{m}$.
- Zone c – Soft Base Material (HB < 190)
Anchorage to the bore of the base material occurs automatically due to the serrations on the sleeve.

Reference:

Base Material of the Installation		
Steel	Cast Iron	Aluminum Alloy
Rz = 10 – 30 µm		Rz = 4 – 30 µm

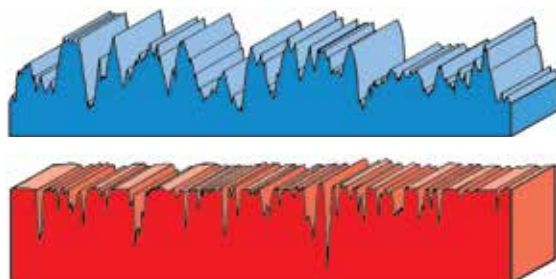

ROUGHNESS PROFILE

Required Roughness Profile

The ideal bore roughness for anchorage is attained by drilling with a twist drill or a core drill.

Undesirable Roughness Profile

By reaming, a one-sided, smooth roughness profile is created. This is not desirable.

DESIGN GUIDELINES FOR KOENIG CHECK VALVE®

WALL THICKNESS / DISTANCE FROM EDGE:

As the radial expansion of the KOENIG CHECK VALVE® sleeve occurs, the base material in which it anchors plastically deforms. The resultant strength, as well as the hydraulic pressure and temperature service conditions depending on the characteristics of the base material, require a minimum wall thickness or distance from edge.

The guideline values for minimum wall thickness and distance from edge ($W_{min.}$) express these influencing factors. At these minimum values, only slight deformation on the exterior profile of the base material of less than 20 μm is likely. This does not affect the function of the KOENIG CHECK VALVE®. Below the guideline values ($W_{min.}$) the possibility of overloading the base material exists, which can adversely influence the function of the KOENIG CHECK VALVE®. In such cases, tests must be conducted.

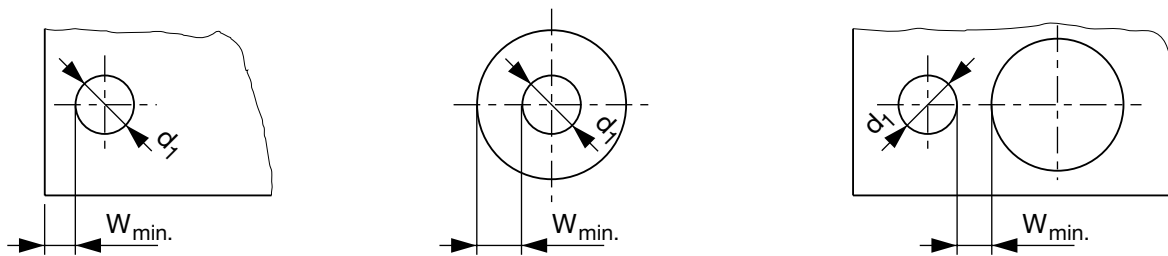

$$W_{min.} = f_{min.} \times d_1$$

Base Material of the Installation				
ETG 100	GJS 600 Ductile Cast Iron	1.4305	A356	Avional
Factor, f min				
0.4	0.5	0.5	0.8	0.5

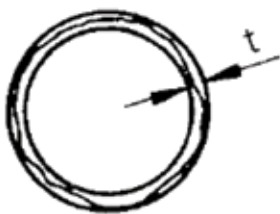

ROUNDNESS TOLERANCE

To ensure reliable functioning of the KOENIG CHECK VALVE® with regard to pressure performance and to ensure leak tight sealing, a roundness tolerance of $t = 0.05 \text{ mm}$ must be held. By using a double-lipped twist drill, the called out hole and roundness tolerances are reached. Better tolerances, particularly for larger diameter holes, can be held by using a triple-lipped twist drill.

CONICITY OF THE BORE

Within the effective anchorage area of the KOENIG CHECK VALVE®, the bore must be in accordance with the dimensional sheets. The bore lead in can be chamfered up to a depth of $0.25 \times d_1$ [check valve diameter] because this area has no significant effect on the anchorage function.

TECHNICAL INFORMATION FOR KOENIG CHECK VALVE®

FLOW CURVES

Valve Characteristics (ΔP vs. Flow), \varnothing 8.0 mm.
FF, 1 bar cracking pressure (T = 50°C, Hydraulic Oil HLP46)

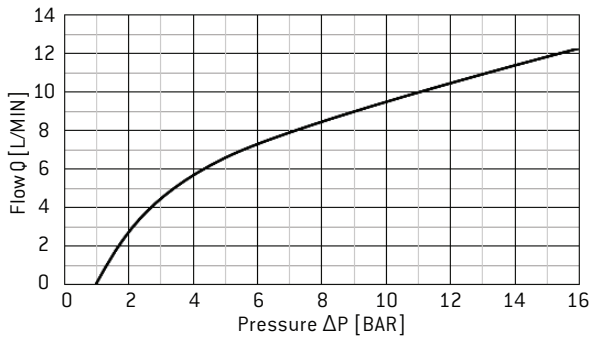

Valve Characteristics (ΔP vs. Flow), \varnothing 8.0 mm.
RF, 1 bar cracking pressure (T = 50°C, Hydraulic Oil HLP46)

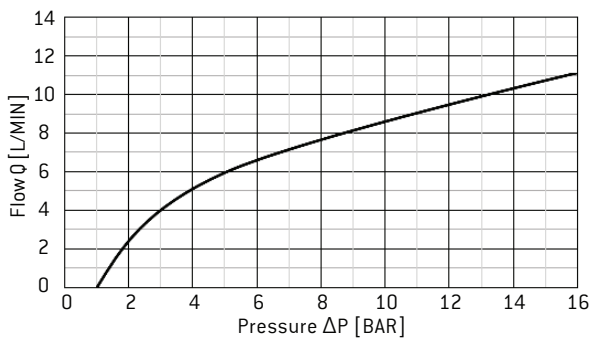

Valve Characteristics (ΔP vs. Flow), \varnothing 5.5 mm.
RF, 1 bar cracking pressure (T = 50°C, Hydraulic Oil HLP46)

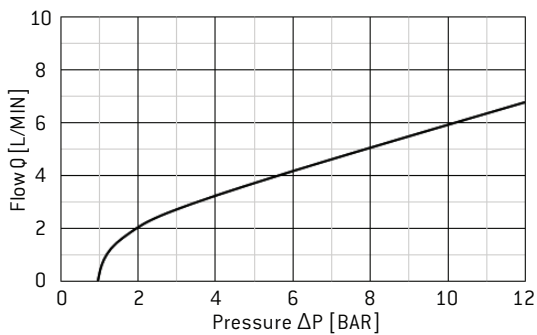

TECHNICAL INFORMATION KOENIG RESTRICTOR®

SFC KOENIG provides several restrictor options for different application requirements, and customers can select the restrictor's orifice size. This allows you to have complete design control – CV expansion and threaded restrictors are custom-made to meet your orifice performance requirements. As with any component in your system design, there are many technical factors to consider. This is one method for calculating orifice diameter for the SFC KOENIG restrictor products.

- This equation was derived by rearranging Bernoulli's Equation and using a Coefficient of Discharge (CD).
- The Coefficient of Discharge (CD) accounts for pressure losses resulting from factors such as orifice geometry, turbulence near the orifice hole, the length of the orifice hole, and flow dynamics.
- This equation for calculating the restrictor orifice diameters should be used as reference only. SFC KOENIG recommends that you perform testing in the actual application environment to determine the flow constant.
- This equation is intended as a guide for fluid applications only; it is not applicable for gas flow applications.

Metric

To calculate restrictor orifice diameter in mm:

$$d_{\text{orifice}} \approx \sqrt{2.144 \times Q \left(\sqrt{\frac{SG}{\Delta p}} \right)}$$

To calculate restrictor flow rate in mm:

$$Q \approx \frac{d_{\text{orifice}}^2}{2.144 \times \sqrt{\frac{SG}{\Delta p}}}$$

Where:

- d_{orifice} > Orifice diameter, measured in mm
- Q > Fluid flow rate, measured in liters/minute
- Δp > Fluid pressure difference across the restrictor, measured in bar
- SG > Specific gravity of the fluid
- 2.144 > Constant = Unit conversion factor x CD

Please visit our web site for a more precise flow calculator formula

Metric

To calculate orifice length in mm:

$$L = (\varnothing \times 0,207) + t$$

L = length of orifice (mm)

\varnothing = orifice diameter (mm)

t = see chart to right

Tolerance: +/- [($\varnothing \times 0.021$) + 0.13] mm

RE Size	t (mm)
4 mm	0.67
5 mm	0.76
6 mm	0.97
7 mm	0.89
8 mm	0.81
9 mm	1.14
10 mm	1.14
12 mm	1.04
14 mm	1.32

TECHNICAL INFORMATION KOENIG RESTRICTOR®

English

To calculate restrictor orifice diameter in inches:

$$d_{\text{orifice}} \approx \sqrt{\frac{Q}{20.89} \left(\sqrt{\frac{SG}{\Delta p}} \right)}$$

To calculate restrictor flow rate in inches:

$$Q \approx \frac{20.89 \times d_{\text{orifice}}^2}{\sqrt{\frac{SG}{\Delta p}}}$$

Where:

- d_{orifice} > Orifice diameter, measured in inches
- Q > Fluid flow rate, measured in gallons per minute (GPM)
- Δp > Fluid pressure difference across the restrictor, measured in PSI
- SG > Specific gravity of the fluid
- 20.89 > Constant = Unit conversion factor x CD

Please visit our web site for a more precise flow calculator formula

English

To calculate orifice length in inches:

$$L = (\emptyset \times .207) + t$$

L = length of orifice (in)

\emptyset = orifice diameter (in)

t = see chart to right

Tolerance: +/- [$(\emptyset \times 0,021) + .005$] in

RE Size	t (inch)
.156"	.027
.187"	.030
.218"	.035
.250"	.038
.281"	.033
.312"	.032
.343"	.045
.375"	.045
.406"	.045
.437"	.052
.468"	.052
.562"	.052

HARDNESS CONVERSION TABLE

For Hardening Carbon and Low Alloy Steel

Tensile Strength 2) N/mm ²	Vickers Hardness (F ≥ 98 n)	Brinell Hardness 1) $\left(0,102 \cdot \frac{F}{D^2} = 30 \frac{N}{mm^2}\right)$	Rockwell Hardness		
			HRB	HRC	HRA
255	80	76,0			
270	85	80,7	41,0		
285	90	85,5	48,0		
305	95	90,2	52,0		
320	100	95,0	56,2		
335	105	99,8			
350	110	105	62,3		
370	115	109			
385	120	114	66,7		
400	125	119			
415	130	124	71,2		
430	135	128			
450	140	133	75,0		
465	145	138			
480	150	143	78,7		
495	155	147			
510	160	152	81,7		
530	165	156			
545	170	162	85,0		
560	175	166			
575	180	171	87,1		
595	185	176			
610	190	181	89,5		
625	195	185			
640	200	190	91,5		
660	205	195	92,5		
675	210	199	93,5		
690	215	204	94,0		
705	220	209	95,0		
720	225	214	96,0		
740	230	219	96,7		
755	235	223			
770	240	228	98,1	20,3	60,7
785	245	233		21,3	61,2
800	250	238	99,5	22,2	61,6
820	255	242		23,1	62,0
835	260	247	[101]	24,0	62,4
850	265	252		24,8	62,7
865	270	257	[102]	25,6	63,1
880	275	261		26,4	63,5
900	280	268	[104]	27,1	63,8
915	285	271	[105]	27,8	64,2
930	290	276		28,5	64,5
950	295	280		29,2	64,8
965	300	285		29,8	65,2
995	310	295		31,0	65,8
1030	320	304		32,2	66,4
1060	330	314		33,3	67,0
1095	340	323		34,3	67,6
1125	350	333		35,5	68,1

Tensile Strength 2) N/mm ²	Vickers Hardness (F ≥ 98 n)	Brinell Hardness 1) $\left(0,102 \cdot \frac{F}{D^2} = 30 \frac{N}{mm^2}\right)$	Rockwell Hardness		
			HRB	HRC	HRA
1155	360	342		36,6	68,7
1190	370	352		37,7	69,2
1220	380	361		38,8	69,8
1255	390	371		39,8	70,3
1290	400	380		40,8	70,8
1320	410	390		41,8	71,4
1350	420	399		42,7	71,8
1385	430	409		43,6	72,3
1420	440	418		44,5	72,8
1455	450	428		45,3	73,3
1485	460	437		46,1	73,6
1520	470	447		46,9	74,1
1555	480	[456]		47,7	74,5
1595	490	[466]		48,4	74,9
1630	500	[475]		49,1	75,3
1665	510	[485]		49,8	75,7
1700	520	[494]		50,5	76,1
1740	530	[504]		51,1	76,4
1775	540	[513]		51,7	76,7
1810	550	[523]		52,3	77,0
1845	560	[532]		53,0	77,4
1880	570	[542]		53,6	77,8
1920	580	[551]		54,1	78,0
1955	590	[561]		54,7	78,4
1995	600	[570]		55,2	78,6
2030	610	[580]		55,7	78,9
2070	620	[589]		56,3	79,2
2105	630	[599]		56,8	79,5
2145	640	[608]		57,3	79,8
2180	650	[618]		57,8	80,0
	660			58,3	80,3
	670			58,8	80,6
	680			59,2	80,8
	690			59,7	81,1
	700			60,1	81,3
	720			61,0	81,8
	740			61,8	82,2
	760			62,5	82,6
	780			63,3	83,0
	800			64,0	83,4
	820			64,7	83,8
	840			65,3	84,1
	860			65,9	84,4
	880			66,4	84,7
	900			67,0	85,0
	920			67,5	85,3
	940			68,0	85,6

Numbers in parentheses indicate hardness values, which are outside the definition area of the standard hardness test, but often used as approximate values. The Brinell values in parenthesis are only used when measured with a hard metal ball.

1) Calculated as: HB = 0,95 x HV

2) The tensile strength values shown in the table are only to be used as approximate values. To get the exact tensile strength values a tensile test must be performed.

SFC KOENIG EXPANDER® SYSTEMS / PRODUCT COMPARISON

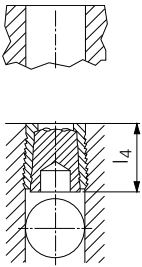
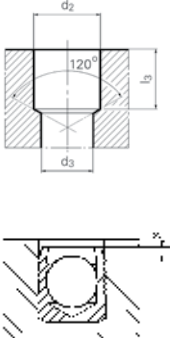
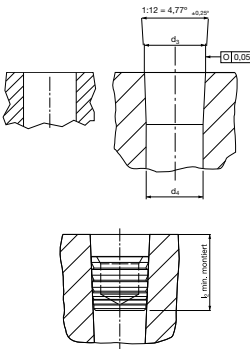
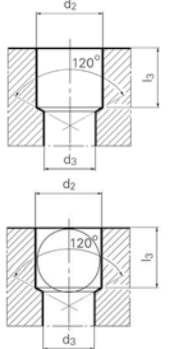
SFC KOENIG EXPANDER® SYSTEMS / PRODUCT COMPARISON				
Type of Sealing Element	Expander Series SK/LK	Expander Series MB/CV	Expander Series LP	Ball
Operations				
Bore	■	■	■	■
Bore (step)	□	■	□	□
Chamfering	□	□	□	■
Face Milling	□	□	□	(■ ³⁾)
Reaming	□	□	□	■
Tapping	□	□	□	□
Cleaning	■	■	■	■
Placing Sealant on Screw	□	□	□	□
Positioning of Element	■ By Setting Tool	■ Put Into Bore	■ By Setting Tool	■
Setting of Sealing Element	■ By Pulling the Mandrel	■ By Setting Tool	■ By Setting Tool	■ By Setting Tool
Cramping	□	□	□	■
Torque Check (in line)	□	□	□	□
Insertion-Control	(■ ²⁾)	(■ ²⁾)	(■ ²⁾)	(■ ²⁾)
Pressure Test	□ Upon Request Only	□ Upon Request Only	□ Upon Request Only	■
Total No. of Operation	4 (5)	5 (6)	4 (5)	8 (10)
Warranty by Supplier	Provided	Provided	Provided	None
Expander Diameter Available	4 – 12/4 – 18 mm	3 – 22/4 – 18 mm	4.4 – 12.7 mm	

¹⁾ = Without Bore Applicable as Well ²⁾ = Optional Control Unit ³⁾ = In Dependence on Assembly □ = Unnecessary ■ = Necessary

SFC KOENIG EXPANDER® SYSTEMS / PRODUCT COMPARISON

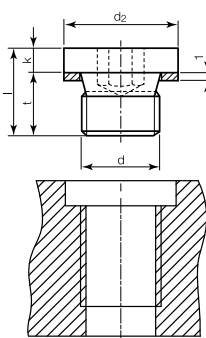
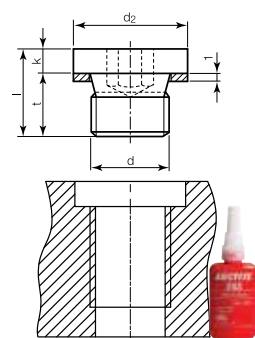
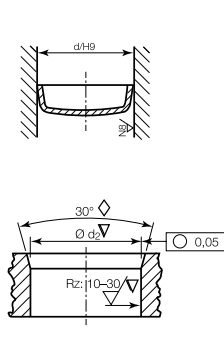
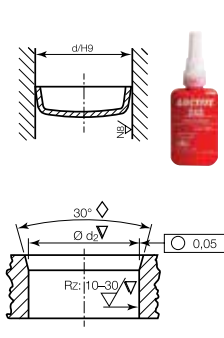
SFC KOENIG EXPANDER® SYSTEMS / PRODUCT COMPARISON				
Type of Sealing Element	Screwed Sealing Plug (metallic sealing)	Screwed Plug with Sealant (e.g. Loctite)	DIN Plug	DIN Plug
Operations				
Bore	■	■	■	■
Bore (step)	■	■	□	□
Chamfering	■	■	■	■
Face Milling	□	□	(■ ³⁾)	(■ ³⁾)
Reaming	□	□	■	■
Tapping	■	■	□	□
Cleaning	■	■	■	■
Placing Sealant on Screw	□	■	□	■
Positioning of Element	■	■	■ By Setting Tool	■ By Setting Tool
Setting of Sealing Element	■	■	■ By Pressing In	■ By Pressing In
Cramping	□	□	□	□
Torque Check (in line)	■ ²⁾	■ ²⁾	□	□
Insertion-Control	□	□	(■ ²⁾)	(■ ²⁾)
Pressure Test	■	■	■ Upon Request Only	■ Upon Request Only
Total No. of Operation	9	10	7 (9)	8 (10)
Warranty by Supplier	None	None	None	None

¹⁾ = Without Bore Applicable as Well ²⁾ = Optional Control Unit ³⁾ = In Dependence on Assembly □ = Unnecessary ■ = Necessary

QUALITY ASSURANCE

At SFC KOENIG quality is our highest priority. Our components meet customers' ever-increasing demands for performance, reliability and safety with efficient and integrated quality and reward management. As the market leader in the area of high-quality sealing technology, our customers predominantly include OEMs and suppliers in the automobile and industrial hydraulics sector. SFC KOENIG is certified according to ISO/TS 16949 and ISO 14001 as well as the aerospace certification AS/EN 9100. We deliver "Total Quality Management" (TQM) to our customers through:

Clear specifications

in cooperation with our suppliers.

Precise instructions and work processes

for all staff.

Rules

for testing.

Process control

in production and installation.

Quality monitoring

using statistical techniques such as SPC, control charts, etc.

Design control

in development, planning and change management.

Staff training

by regular internal auditing and implementation of quality circles.

Important:

All KOENIG EXPANDER®, KOENIG RESTRICTOR® and KOENIG CHECK VALVE® products are identified by batch numbers (production serial number) on the package label. This batch number ensures traceability of all quality-related characteristics of production and procurement.



KOENIG EXPANDER®		
LK 600-080		8,0 MM
300162299	300162299	SWISS MADE
	Batch 1000548963	
	Anzahl 500	
HÜLSE NICHTRÖST STAHL 1.4305 DOUILLE ACIER INOX 1.4305 STIFT NICHTRÖST STAHL 1.4542 MANDRIN ACIER INOX 1.4542		
Quality System: ISO/TS 16949 ISO 9001/ISO 14001 EN 9100		SFC KOENIG Leader in Sealing & Flow Control Technology
KD.ART.NR.		

NOTES

SFC KOENIG DISTRIBUTOR LIST



AUSTRALIA

SCHILTEC
NSW 2122
Eastwood
Phone +61 (0)2 9876 4310
schiltec@gmail.com
www.schiltec.com.au

AUSTRIA

KVT-Fastening GmbH (Austria & CEE)
Bahnhofstrasse 1
4481 Asten
Phone +43 (0) 7224 67 09 0
info-at@kvt-fastening.com
www.kvt-fastening.at

BELGIUM

DEJOND NV
2610 Wilrijk (Antwerpen)
Phone +32 (0) 3 820 34 11
info@be.dejond.com
www.dejond.com

BRAZIL

GEPEF
18550-000 Boiuva – SP
Phone +55 (0) 15 3363 39 25
gepef@gepef.com.br
www.gepef.com.br

DENMARK

A/S GUNNAR HAAGENSEN
3450 Allerød
Phone +45 (0) 48 17 65 00
gunnar@haagensen-as.dk
www.haagensen-as.dk

FINLAND

COLLY COMPONENTS AB
164 94 Kista
Phone +46 (0) 8 703 01 00
components@colly.se
www.collycomponents.se

GERMANY

KVT Fastening GmbH
Max-Eyth-Strasse 14
89186 Illerrieden
Phone +49 (0) 7306 782 0
info-de@kvt-fastening.com
www.kvt-fastening.de

INDIA

AVLOCK International Private Ltd.
400 020 Mumbai
Phone +91 (0) 22 6634 5611
koshi.thomas@avlock.co.in

ITALY

UNIFAST SRL
10036 Settimo Torinese
Phone +39 (0) 11 816 5511
info@unifast.com
www.unifast.com

JAPAN

MATSUI CORPORATION
Tokyo 106-8641
Phone +81 (0) 33 586 4141
info@matsui-corp.co.jp
www.matsui-corp.co.jp

KOREA (REPUBLIC OF)

SAMJIN CORPORATION
137-729 Seoul
Phone +82 (0) 2 581 5692
jb@samjinworld.co.kr
www.samjinworld.co.kr

NORWAY

COLLY COMPONENTS AB
164 94 Kista
Phone +46 (0) 8 703 01 00
components@colly.se
www.collycomponents.se

NETHERLANDS

VIBA NV
2700 AK Zoetermeer
Phone +31 (0) 79 330 67 00
viba@viba.nl
www.viba.nl/nl

SWEDEN

COLLY COMPONENTS AB
164 94 Kista
Phone +46 8 703 01 00
components@colly.se
www.collycomponents.se

SOUTH AFRICA

ALBA HYDRAULICS PTY LTD
1610 Edenglen
Phone +27 (0) 11 458 1200
info@alba.co.za
www.alba.co.za

SPAIN

ITALMATIC SA
20115 Astigarraga
Phone +34 (0) 943 335 633
italmatic@italmatic.es
www.italmatic.es

SWITZERLAND

KVT-Fastening AG
Lagerstrasse 8
8953 Dietikon
Phone +41 (0) 44 743 33 33
info-ch@kvt-fastening.com
www.kvt-fastening.ch

UNITED KINGDOM

BONEHAM & TURNER LTD
Sutton-in-Ashfield NG17 5FS
Phone +44 (0) 1623 445 450
sales@boneham.co.uk
www.boneham.co.uk

SFC KOENIG BRANCHES

Headquarters - Switzerland

SFC KOENIG AG

Lagerstrasse 8
8953 Dietikon
Phone +41 44 743 46 00
info-ch@sfckoenig.com

Germany

SFC KOENIG GmbH

Max-Eyth-Strasse 14
89186 Illerrieden
Phone +49 7306 2062 300
info-de@sfckoenig.com

China

SFC KOENIG Suzhou

Room NW02-211, 99 Jinji Lake Avenue
Nanopolis Suzhou
Phone +86 512 6585 9515
info-cn@sfckoenig.com

United States of America

SFC KOENIG LLC

73 Defco Park Road
North Haven, CT 06473
Phone +1 203 245 1100
info-us@sfckoenig.com



KOENIG EXPANDER®

KOENIG CHECK VALVE®

KOENIG RESTRICTOR®



 **Headquarters - Switzerland**
SFC KOENIG AG

Lagerstrasse 8
8953 Dietikon
Phone +41 44 743 46 00
Fax +41 44 743 46 01
info-ch@sfckoenig.com

 **Germany**
SFC KOENIG GmbH

Max-Eyth-Strasse 14
89186 Illerrieden
Phone +49 7306 2062 300
Fax +49 7306 2062 399
info-de@sfckoenig.com

SFC-KOENIG

Leader in
Sealing & Flow Control
Technology

Browse our website or contact us to learn more about the entire range of SFC KOENIG products, applications and capabilities.

 **USA**
SFC KOENIG LLC

73 Defco Park Road
North Haven, CT 06473
Phone +1 203 245 1100
Fax +1 203 245 3072
info-us@sfckoenig.com

 **China – SFC KOENIG Flow Control (Suzhou) Co., Ltd.**

Room NW02-211, Nanopolis Suzhou
99 Jinji Lake Avenue, Suzhou Industrial Park, Jiangsu Prov. P.R.China. 215123
Phone +86 512 6585 9515
Fax +86 512 6561 1718
info-cn@sfckoenig.com

Specifications subject to change without notice.

www.sfckoenig.com