

Multi-connection programme MCS

Component guide





Improving the quality ...

Stäubli are experts in industrial connection and are always developing their know-how in all industrial sectors:

- Automotive
- Engineering
- Aeronautics
- Plastics
- Railways
- Off-shore
- Nuclear
- Iron and Steel

A precise specification

is established in conjunction with you, the customer, to define the unique parameters of your application:

- type of fluid
- pressure
- temperature
- flow
- type of valving (single shut-off, double shut-off or unvalved)
- type of fitting
- non-spill requirements
- electrical connector requirements: amperage, voltage, number of pins
- consideration of environmental constraints such as: temperature, particular climatic conditions, marine environment ...
- misalignment
- frequency of connections / disconnections
- space envelope available ...

We design and manufacture complete personalised solutions

based on standard components:

- modular couplings and electrical connectors
- guiding and floatability components
- connection and locking systems ...

to meet your specific requirements.

Time saving

Quick and simultaneous connection of all services: pneumatics, liquids, gases, hydraulics and electrics.





... and the performance in production

Safety

Connection in one position only: no possibility of mistakes caused by circuit inversion.

Plate locking in connected position adapted to your conditions of use.

Seals suited to the fluid and to the application.

Reliability

Our multi-couplings are designed for a large number of connections and disconnections.

Innovation and performance

Our desire to innovate combined with our experience of connections in industrial applications allow us continually to develop our multi-coupling ranges to meet your expectations and new technological requirements.

Simple and cost effective solutions for custom made multi-connections

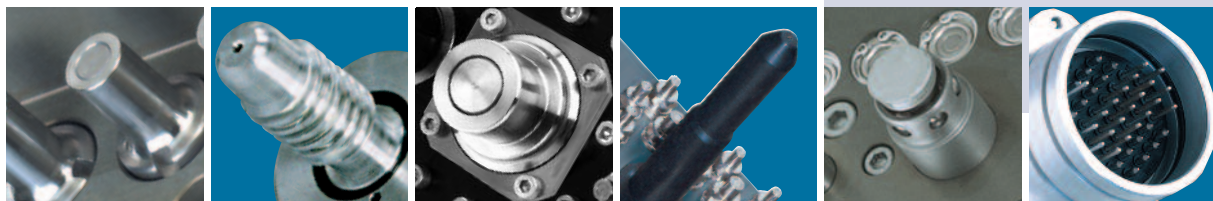

Summary

Coupling components

- Antipollution on hydraulics p. 4
- Antipollution on high pressure hydraulics p. 5
- 100 % integrated and antipollution on high pressure hydraulics p. 6
- Pneumatics, liquids and gases p. 7
- Electrical connectors p. 8

Guiding and floatability p. 9

Connection and locking

- Manual systems p. 10-11
- Automatic systems p. 12-14

Pre-defined systems p. 15



SPH antipollution on hydraulics

For hydraulic circuits and working areas

- Extended range.
- Excellent flow in either direction (socket to plug or plug to socket).
- Installation into pocket for easy maintenance.
- Individual plugs and sockets available for Ø 04, 06, 08 and 12 mm for sampling or individual circuit testing.
- Back adaptors are interchangeable between plugs and sockets.

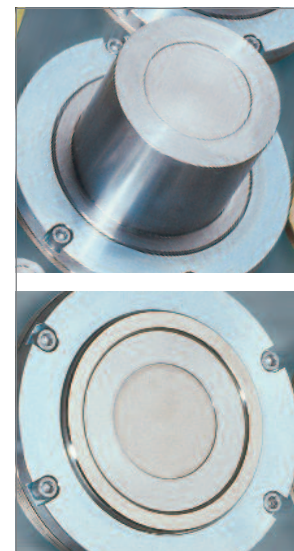
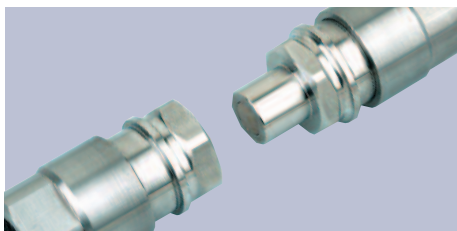

Range

Ø 04 - 06 - 08 - 12 - 15 - 20 - 25 - 37 - 50 - 75 mm on MA version.

Ø 04 to 12 mm on MP version.

Max. working pressure (bar)

depends on diameter and materials

Ø (mm)	04	06	08	12	15	20	25	37	50	75
Standard	-	-	-	-	-	-	16	16	16	10
IA	160	160	160	160	160	160	-			
IB	500	500	500	250	250	250	250			

Materials

3 versions, depending on diameter of flow, for low, medium or high pressure.

- standard - Ø 25 to 75 mm: 18/9 stainless steel and brass with surface treatment.
- IA - Ø 04 to 20 mm: high resistance stainless steel, stainless steel with 17% chrome content and brass. BF (Brass free) option available for IA version.
- IB - Ø 04 to 25 mm: high resistance stainless steel and 18/9 stainless steel.

Seals: Nitrile (NBR) as standard.

Available as option: Fluorocarbon (FPM), Ethylene-Propylene (EPDM), Perfluoroelastomer (FFKM), or Fluorosilicone (FMQ), from SPH 04 to SPH 50.

Polyurethane (PU) in the fluid jet, from SPH 06 to SPH 20.



HPX / MA high pressure hydraulics

For use on demanding static and dynamic applications
Harsh working environment: hydroforming, steel industry ...
High pressure pulsating or vibrating hydraulic lines

- Range developed from Stäubli proven mono-coupling applications.
- Non-spill.
- Protected sealing.
- Minimum pressure drop: direct flow path with no interruption to fluid flow and consequent turbulence.

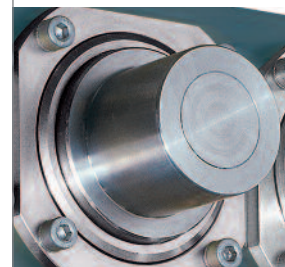
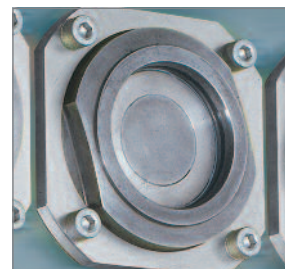

Range

Ø 08 – 12 – 20 – 25 – 33 mm

Max. working pressure (bar)

Ø 8 to 25 mm: 500 bar

Ø 33 mm : 350 bar

Materials

Predominately stainless steel with high mechanical resistance.

Seals: Nitrile (NBR) as standard.

Available as option: Fluorocarbon (FPM).

Polyurethane (PU) in the fluid jet.

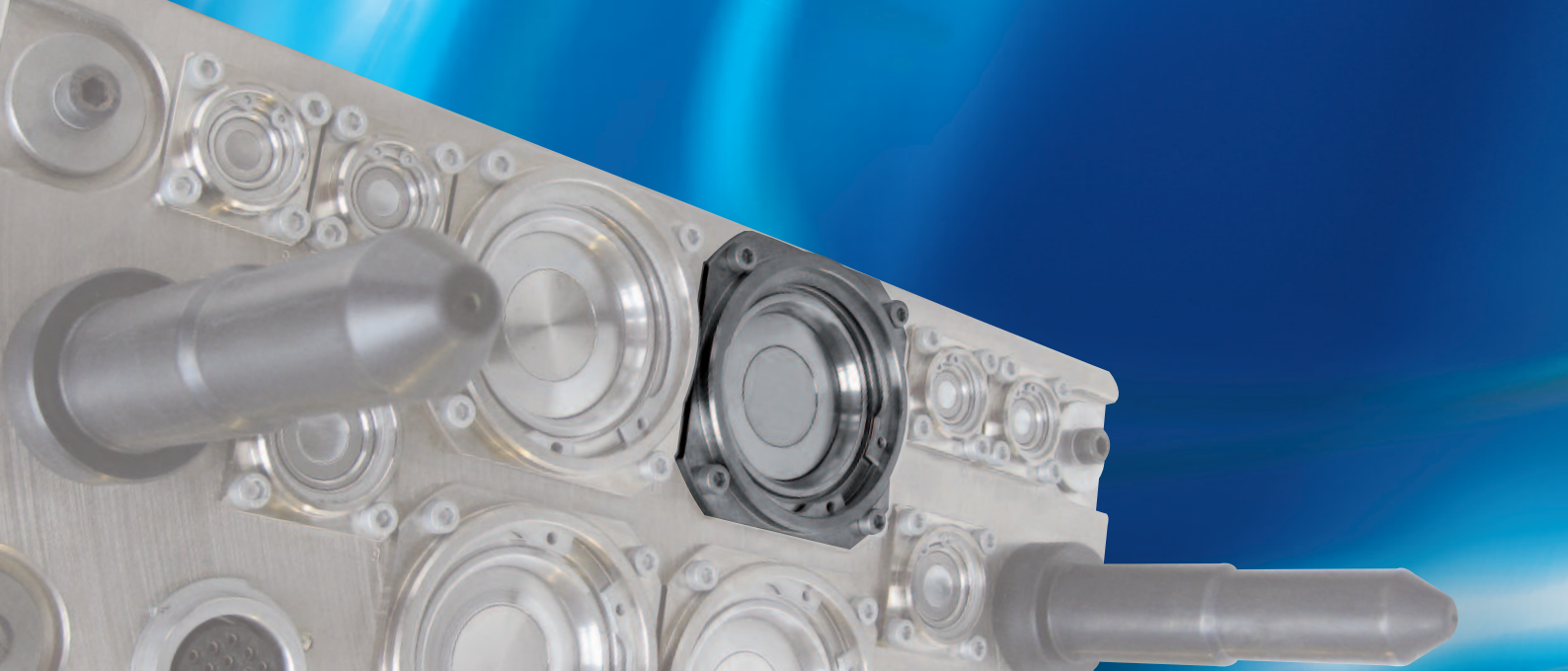

SPC antipollution on high pressure hydraulics

Compact for a complete integration into high pressure hydraulic systems

- Installation of plugs and sockets into pockets for space saving.
- Facilitated maintenance: easy to replace the plugs and sockets without previous dismounting of the hose.
- 0 interface gives additional space saving.
- Take-up of misalignment at connection.
- Optimal flow in a reduced space envelope.
Full flow is preserved even if connection stroke is not completed (tolerance of 2 mm).
- Non spill flat face design.
- **Reliability:** the SPC is designed for high frequency usage up to 1 million connections.

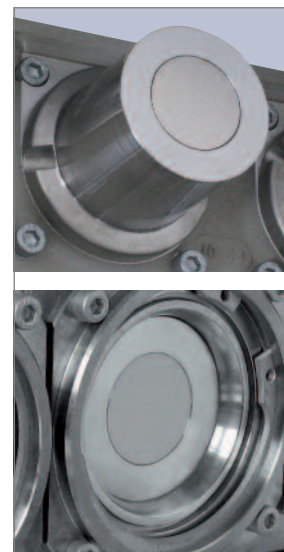
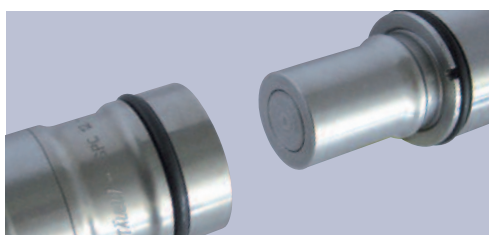

Range

Ø 03 – 05 – 08 – 12 – 20 mm

Max. working pressure (bar)

depends on diameter

Ø (mm)	03	05	08	12	20
Pressure (bar)	450	300	250	160	160

Materials

High resistance stainless steel.

Seals: Nitrile (NBR) as standard.

Available as option: Ethylene-Propylene (EPDM) and Fluorocarbon (FPM).

Perfluoroelastomer (FFKM) in the fluid jet, from SPC 03 to SPC 12.

Other options available: consult us.

2 versions

- pocket recessed both sides into drilled holes,
- threaded plug and recessed socket.



RMA/RMP pneumatics, liquids and gases

Extensive modular range with a considerable number of options

- Based on proven Stäubli RBE technology.
- Stepped guiding.
- High resistance steel.
- RBE range couplings may be connected to RMA / RMP plugs.

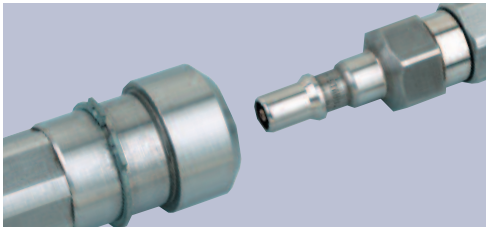

Range

5 sizes of couplings: Ø 03, 06, 08, 11 and 19 mm.

Alternative materials depending on the applications:

- standard: for compressed air, gases, oils and hydrocarbons ...
- IA: for water, air, gases, oils...
- IA / HPL: for high pressure liquids (only on RMA range)
- IA / W: for primary vacuum to 10^{-3} torr

7 seal options.

3 shut-off options: single, double or unvalved.

Max. working pressure (bar)

depends on diameter of flow and construction:

- standard and IA : 50 bar
- IA / HPL : depends on diameter, only on RMA range

Ø (mm)	03	06	08	11	19
Pressure (bar)	400	450	400	350	300

- IA / W : 10^{-3} torr



Materials

- standard: mostly stainless steel with 17% chrome content. Socket back adaptor in steel treated against corrosion.
 - IA: mostly stainless steel with 17% chrome content
 - IA / HPL: stainless steel with 17% chrome content and AISI 316L stainless steel (only on RMA range).
 - IA / W: internal components AISI 316L stainless steel.
- Seals: Nitrile (NBR) as standard,
Available as option : Fluorocarbon (FPM), Ethylene-Propylene (EPDM), Perfluoroelastomer (FFKM), Fluorosilicon (FMQ), Chloroprene (CR).



REA/REP electrical connectors

Electrical circuits from high current to BUS-signal and from power to thermo-couple applications
Wide range of housings, insulators and contact types

- **Safety**

- No risk of misconnection: housings and inserts are totally indexed on the plates.
- Metal or plastic housings protected against dust and liquid splashes.
- Insulators with incorporated earth contact (first mate, last break).
- Metal housings with screw incorporated for earthing.

- **Reliability**

High current carrying capacity with minimal contact resistance for long life span.
 Excellent resistance to temperature and vibration of crimped contacts.

- **Ease of maintenance**

Quick replacement of the complete housings on pre-wired harness.
 Assembly and disassembly of the insert from the rear without removing the body of the housing from the plate.

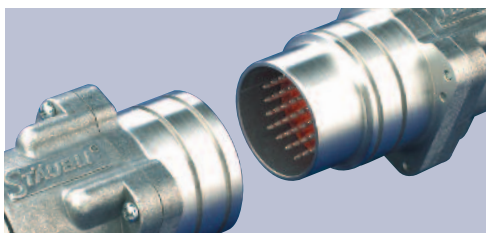
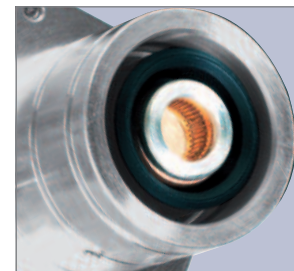

Materials

- Housings: aluminium, stainless steel or plastic, (POM/fiber-glass reinforced PA). Shielded and shielded-insulated housings available.
- Insulators: NBR synthetic rubber, Silicone, Chloroprene and PEEK.
- Contacts: Silver or gold plated copper alloy. Crimp termination. Female contacts equipped with proven Multilam technology.

Range

- Housing: 4 sizes with either straight or 90° cable outlet.
- Insulators : 20 different types from 1 to 72 poles.
- Contacts: 40 different types from Ø 1 mm to Ø 11 mm including spring-loaded and thermocouple pressure contacts.

Norms

Ingress protection to IP65/67 (mated) and IP2X (unmated) according to EN 60529 and IEC 60529 standards.
 Clearance and creepage distances according to EN 60664-1 and IEC 60664 standards
 DIN EN 61984, VDE 0627
 DIN VDE 0298-4, VDE 0298-4.

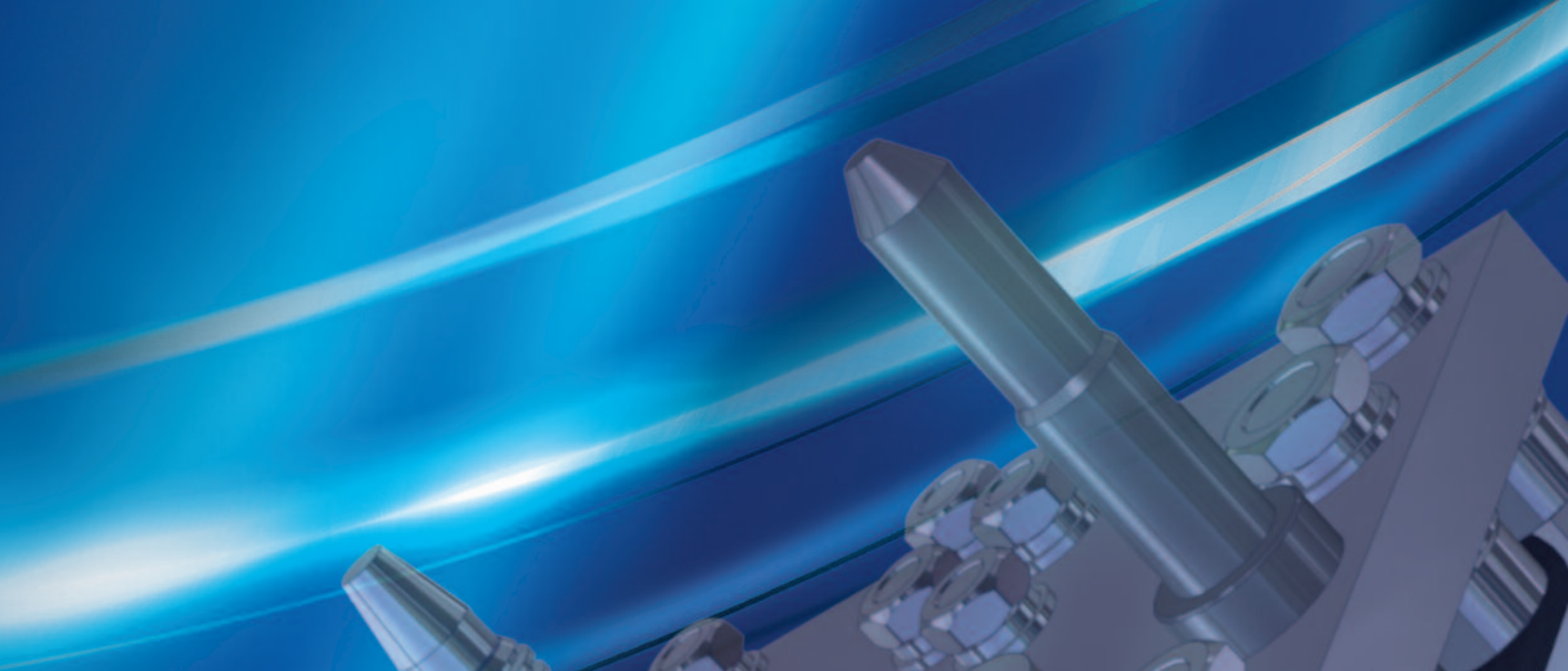

Guiding and floatability

Guiding technology is always associated with the floatability technology

Guiding pins

They remove any misalignments.

- Pre-guiding of the plates to align correctly.
- Precise guiding of the plates before coupling connection.
- Operation of mechanical end stop.
- Various alternative shapes and lengths of guide pins, depending on the positioning errors of the plates to be connected.



Floatability components

They ensure removal of misalignments.

- Mechanical elastic device (spring or spring washers).
- Elastic device incorporating rubber washers (elastic bushes).





Connection and locking - Manual systems

Push button

For smaller dimensioned plates and low pressure applications:

- connection by simply pushing plates together
- disconnection by pushing the button

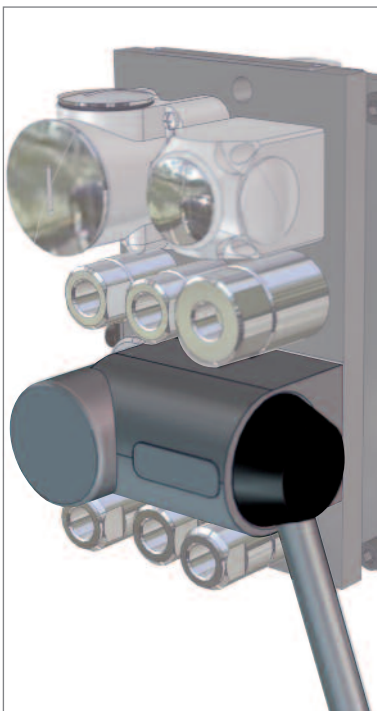
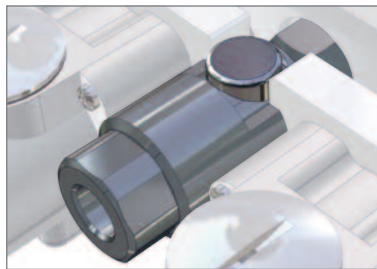

Lever

• rack mechanism

for medium sized plates and high pressure applications:

- robust design
- balanced connection forces

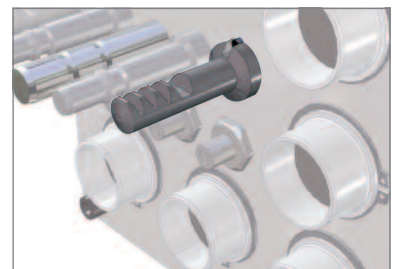

• ball lock

for small or medium sized plates and low or high pressure applications:

- robust locking with a large number of locking balls
- connection and disconnection via a simple rotation movement of a lever
- optional safety feature which prevents accidental unlocking



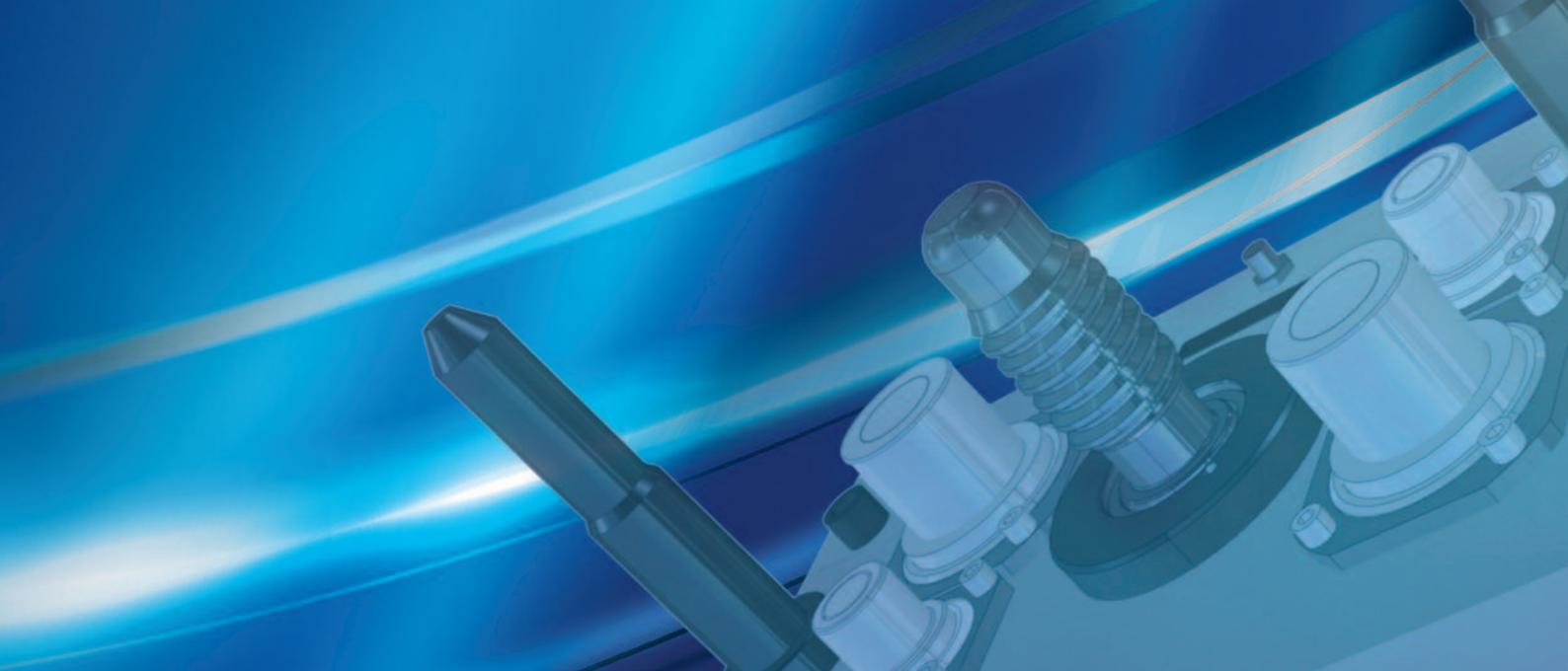

Connection and locking - Manual systems

Screw lock

for large plates and large bore couplings,
in cases where connection forces are significant,
high pressure applications:

- may be used for manual connection of multi-coupling plates (eg on mould pre-heat stations) onto automatic plates
- safety locking via irreversible screw thread
- quick-screw thread

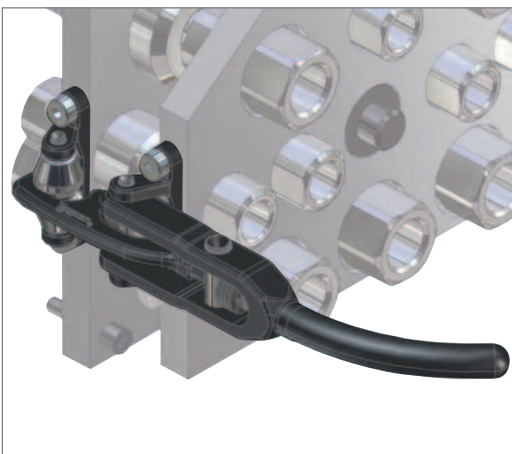

Handle

• toggle clamp locking

for small and medium sized plates and high pressure applications:

- anti-accidental unlocking safety feature via toggles making accidental unlocking impossible
- simple and very robust design
- particularly suited to demanding environmental conditions

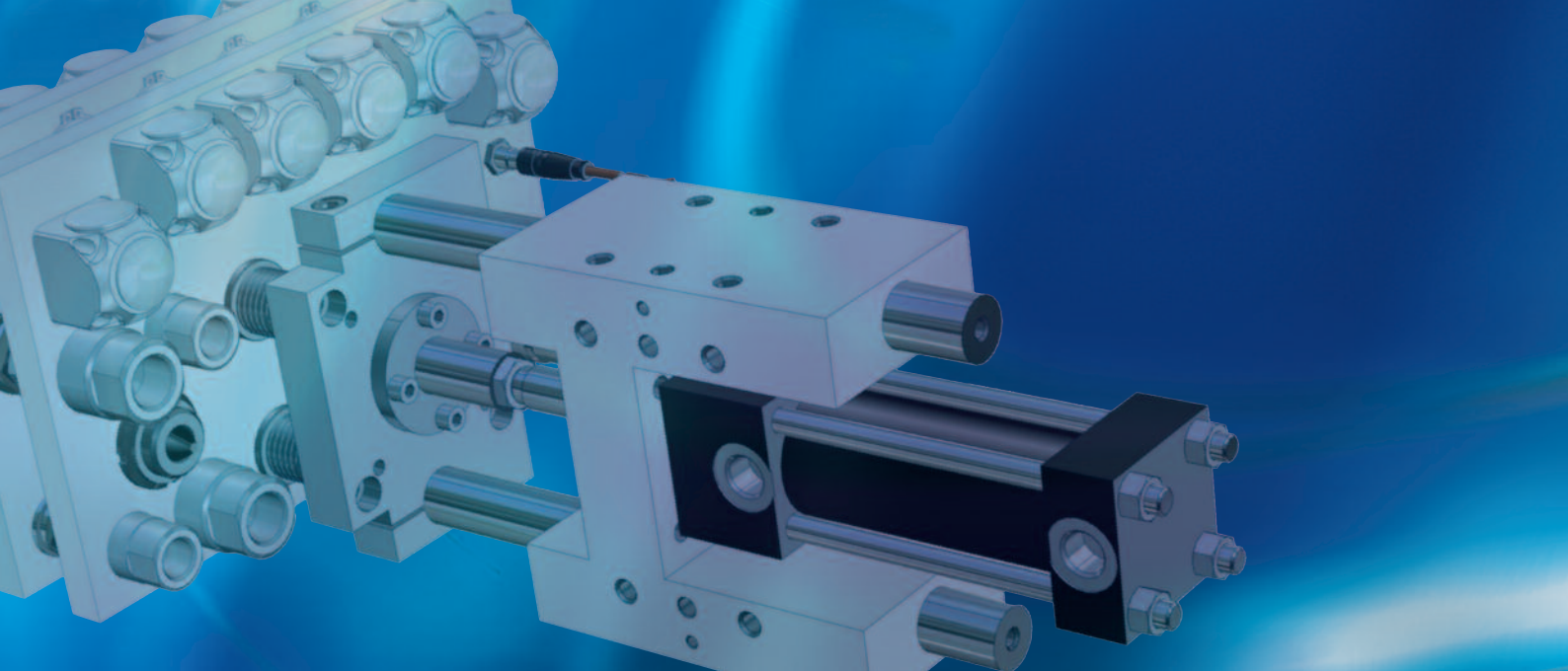

Connection and locking - Automatic systems

Connection systems

- **guiding units fitted with pneumatic or hydraulic cylinder**

for medium sized plates.

They forward movement of plates and ensure their guiding and connection:

- automatic connection
- monitoring of locked and unlocked positions via proximity switch

Unit fitted with:

- **pneumatic cylinder**
for low pressure applications

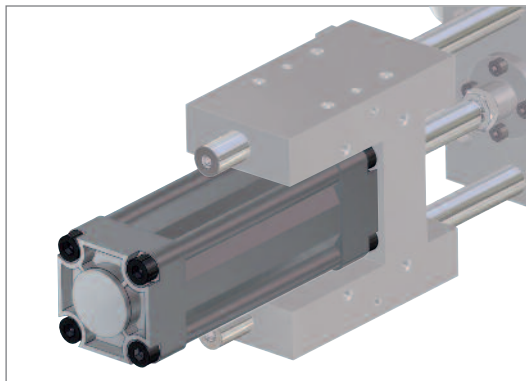

- **hydraulic cylinder**
for medium or high pressure applications

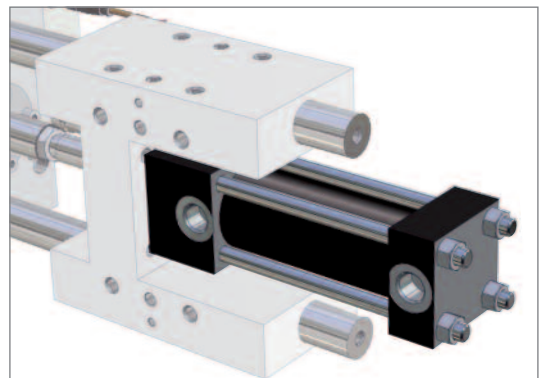



Locking systems

- **by locking jaw**

for small, medium and large sized plates and high pressure applications:

- particularly suited to demanding environmental conditions

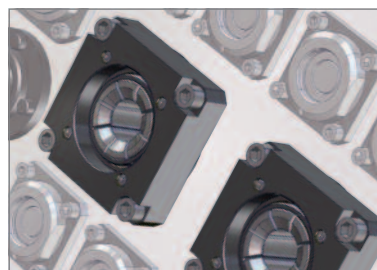

- **by bolt**

for medium and large sized plates and high pressure applications.

They ensure a mechanical locking of the plates at limit stop:

- unlocking by pneumatic or hydraulic control
- monitoring of locked and unlocked positions via proximity switch

Bolt ensuring a locking resistance up to 1.5 tons for small and medium sized plates

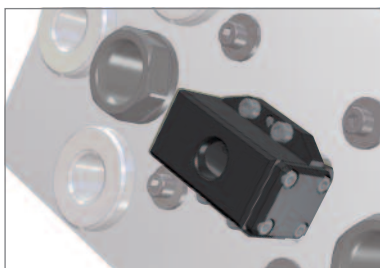

Bolt ensuring a locking resistance up to 10 tons for medium and large sized plates

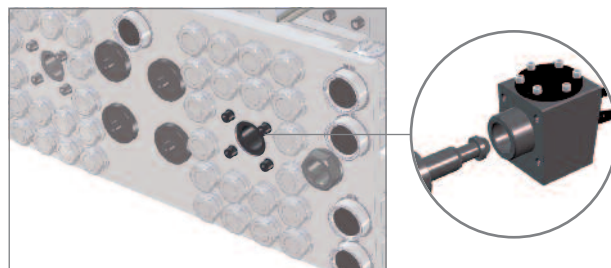

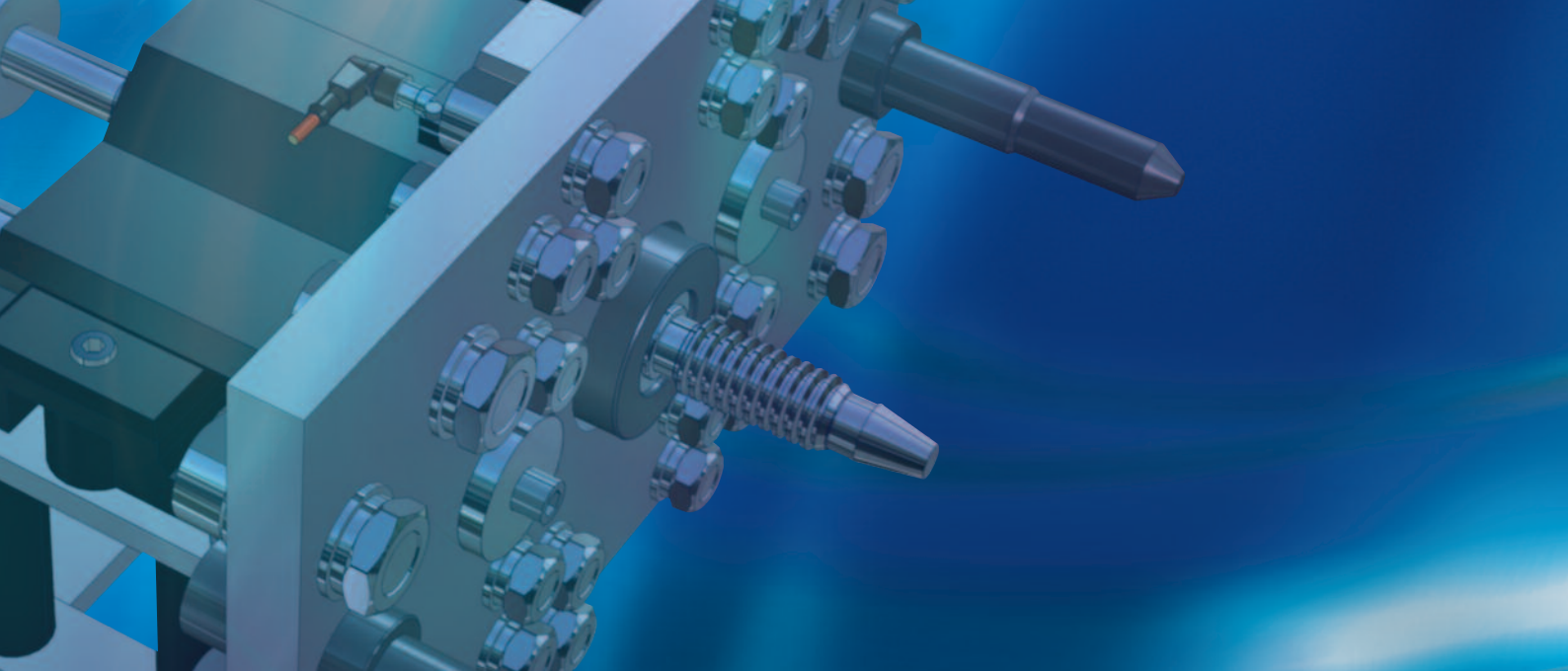

Connection and locking - Automatic systems

Connection and locking systems

- **screw lock**

for large sized plates and high pressure applications.

They forward movement of plates and ensure their guiding and connection:

- 2 versions, depending on connection stroke
- patented double irreversible screw-lock system which removes forces acting on customer-side support brackets by absorption of connection forces
- monitoring of connected and disconnected positions via proximity switch

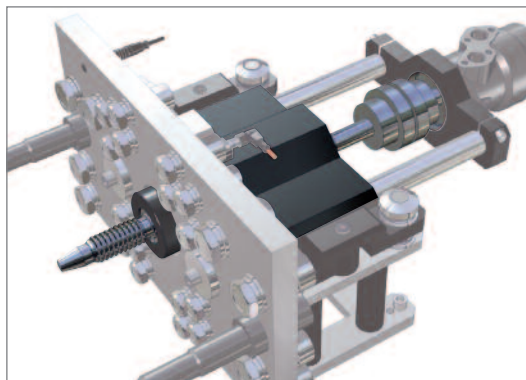

- **integrated locking**

for medium sized plates and low to medium pressure applications.

They ensure the mechanical locking of plates as well as their connection and disconnection:

- locking by simply pushing the plates together
- unlocking, connection and disconnection via pneumatic or hydraulic control

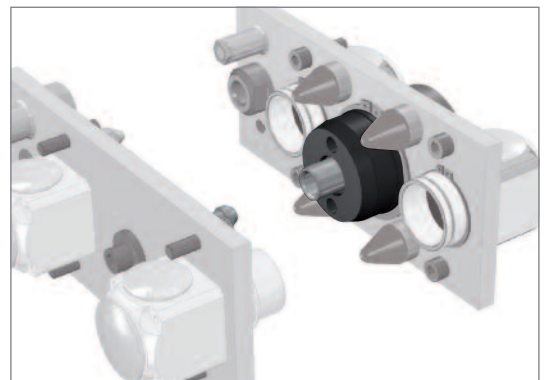

Pre-defined manual systems of centralised connection constitute ready for use solutions for some of your applications

- **MCI and RMI plates**

Temperature control circuits (water, hot oil).



- **RMP plates**

High pressure hydraulic circuits, power supply to ejection cylinders, core pullers...



- **SPC plates**

Centralised supply to hydraulic cylinders controlling the opening and closing needles of sequential injection nozzles.

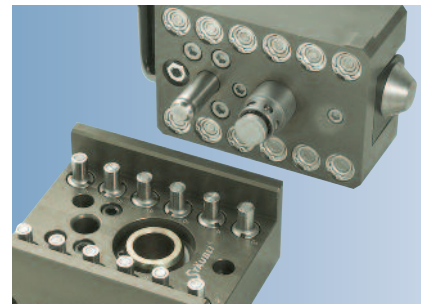

- **REP plates**

Centralised connections of wire bundles for data processing and power electric circuits.

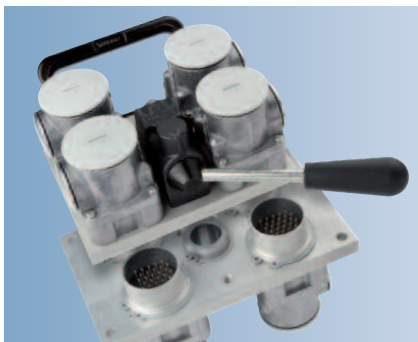

- **CombiTac Programme**

Modular assembly design for energy circuits : pneumatic, fluids, hydraulic, power, signal, thermocouple, coaxial, fibre optic and bus connections.



To define the most suitable solution for your application, consult the team of Stäubli Senior Sales Engineers

For contact details: www.staubli.com/connectors/contacts



Global presence of the Stäubli Group

- Stäubli units
- Agents

International sales coordination

Stäubli Faverges - CS 30070 - F - 74210 Faverges - Tel.: +33 4 50 65 67 97 - Fax: +33 4 50 65 60 69 - E-mail: connectors.sales@staubli.com
www.staubli.com

Stäubli is a trademark of Stäubli International AG, registered in Switzerland and other countries. © Stäubli 18/12/2014. Printed on FSC paper.
We reserve the right to modify product specifications without prior notice. Photocredits: Stäubli.

RZ5150301C